



Tractors

AXION

850 820



The AXION 800 from CLAAS.

AXION 850 / 820



Impressive in every way.
The AXION 800.

As one of the leading manufacturers of agricultural machinery, CLAAS is uniquely placed to understand what really matters to the farming community. Outstanding versatility, the greatest possible comfort, intelligent technology and above, all value for money – these are the factors that count.

Packed with power.

With maximum engine output of 233 hp¹, the AXION 800 is the ideal basis for a broad range of tasks. Whatever the application, its intelligent engine management system ensures that fuel consumption remains low.

Good to go.

The intuitive, ergonomic controls on the AXION 800 hold no mysteries. Drivers can instinctively find their way around right from the start. The logically arranged functions and exceptional comfort enable them to relax even during long working days.

A real worker.

All the components and systems on the AXION 800 are designed for outstanding reliability and a long service life. It won't let you down.

¹ Rated output in compliance with ECE R 120



CLAAS POWER SYSTEMS. Plenty of power under the bonnet – and up to 35 hp in reserve.
Page 8



HEXASHIFT transmission. The optimum speed, automatically.
Page 10

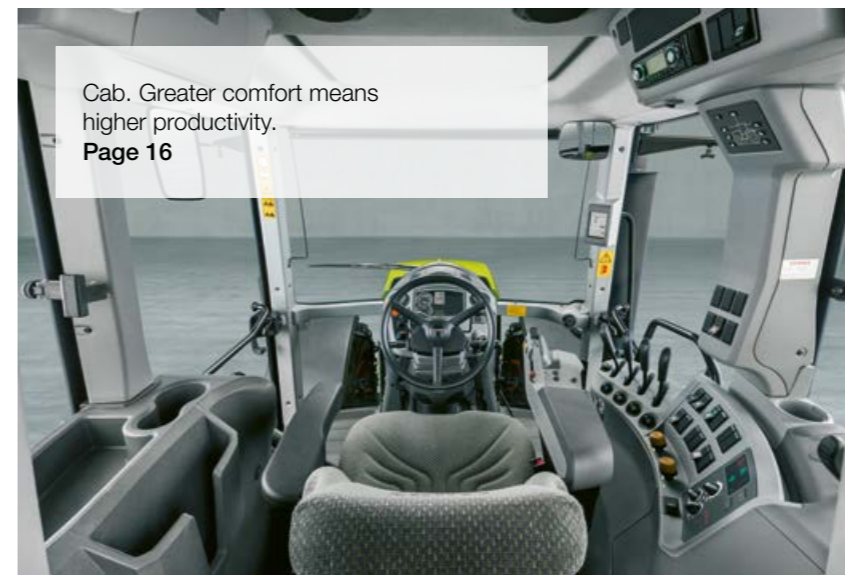

Cab. Greater comfort means higher productivity.
Page 16



Hydraulics. 110 l/min output lifts even the heaviest of implements.
Page 14



Digital Farming. For greater precision and efficiency.
Page 22



Maximum tractive power. Short overall length, long wheelbase, perfect weight distribution.
Page 12

Impressive in every way. The AXION 800. 2

CLAAS POWER SYSTEMS 6

- Engine 8
- Transmission 10
- Construction 12
- Hitches 14

Cab and comfort 16

- Armrest, joystick, on-board information system 18
- Comfort 20

Operator assistance systems and data management 22

- The terminal 24
- ISOBUS functions 26
- Data management 28

- Maintenance 30
- CLAAS Service & Parts 32

Features 34

Technical data 35

Our drive system is the perfect combination of the best components.

Your CLAAS machine is much more than the sum of its individual parts. Top performance is only possible when all parts are ideally matched and work together optimally.

In CLAAS POWER SYSTEMS (CPS), we have brought together top-quality components to create an intelligent drive system that sets new standards. Full engine output only when you need it. Drives that are suited to the way your machines are used. Fuel-saving technology which quickly pays off.

CPS | CLAAS
POWER
SYSTEMS



Plenty of power under the bonnet – and up to 35 hp in reserve.

Get more done.

A constant power range of 400 rpm and a torque increase of 40% are the impressive performance statistics presented by the AXION 800. But higher output doesn't necessarily imply higher consumption.

AXION	Rated output (hp)	Maximum output (hp)	Additional CPM performance boost (hp)
850	233	238	30
820	189	197	35

On the contrary – thanks to the engine technology used here and CLAAS POWER MANAGEMENT (CPM), not a single litre of valuable diesel is wasted. Additional output is only mobilised when it is required.

The automatic HEXASHIFT transmission makes another valuable contribution, allowing you to work efficiently and economically. Its outstanding efficiency puts it in a class of its own and guarantees just the right engine and working speed in any application. Regardless of the speed you work at, low operating costs are our first priority.

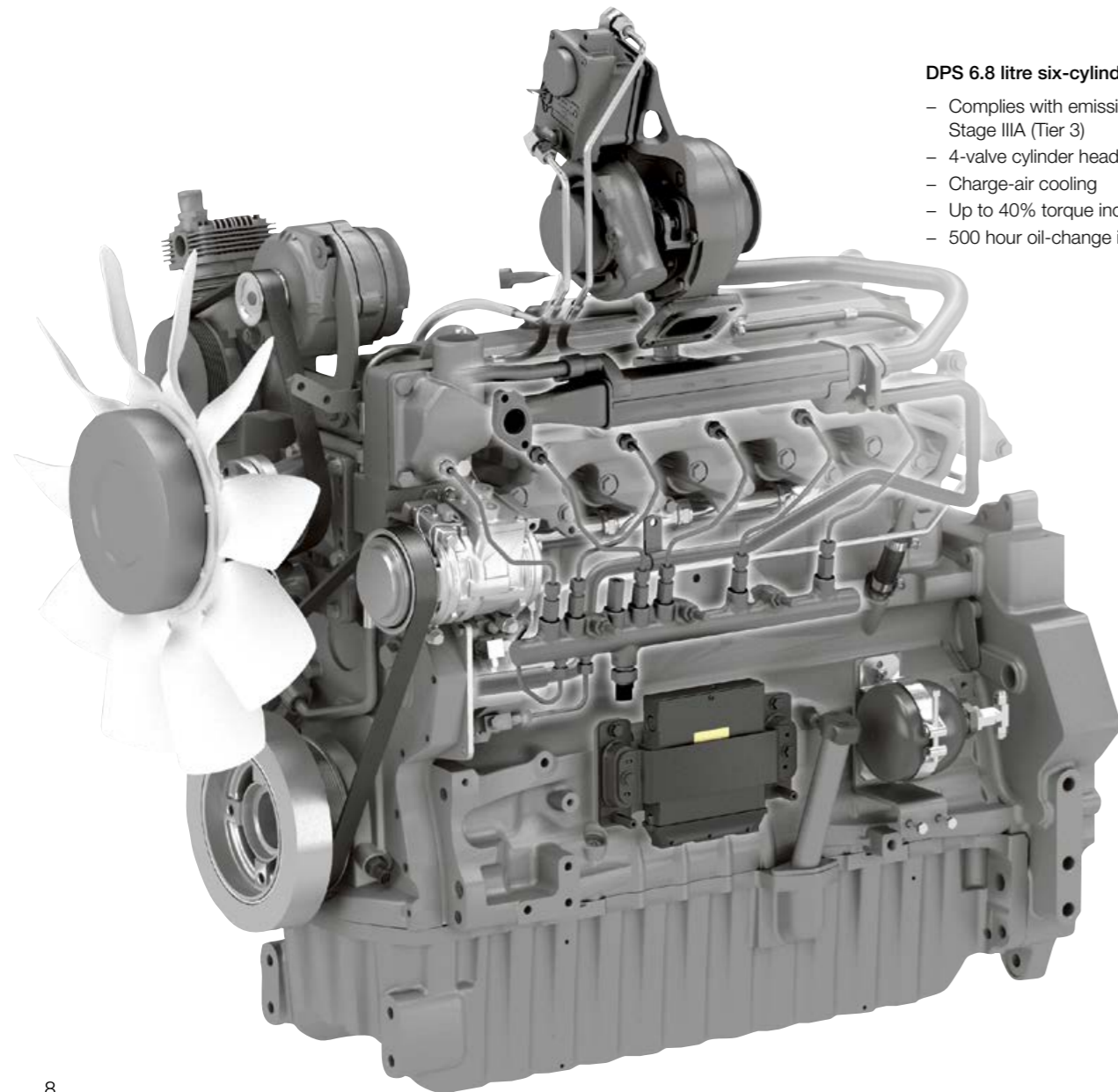

DPS 6.8 litre six-cylinder engine.

- Complies with emission standard Stage IIIA (Tier 3)
- 4-valve cylinder head
- Charge-air cooling
- Up to 40% torque increase
- 500 hour oil-change interval



CLAAS POWER MANAGEMENT (CPM).

All AXION 800 models are fitted with the electronic CPM control system. Depending on the tractive power requirement, PTO output or hydraulic power decrease, up to 35 hp additional engine performance will be gradually released under the following conditions:

- Transmission in range C or D (C1 = 6 km/h)
- If hydraulic output is decreasing
- If PTO output is decreasing

The CPM releases the additional boost power in six stages, so it never releases more fuel-hungry power than is actually required.

Variable geometry turbo (VGT)

For a high torque, even at low engine speeds, the turbine blades are adjusted depending on speed and load. This means no more 'turbo lag'.

Cooled exhaust gas recirculation.

The recirculation of part of the exhaust gas flow significantly reduces pollutant emissions. Supplementary cooling optimises the combustion process and reduces fuel consumption.

The benefits for you.

- Maximum tractive power with the DPS 6.8 litre six-cylinder engine with variable turbocharger
- Cooled exhaust gas recirculation saves fuel
- The perfect speed in any application with CLAAS POWER MANAGEMENT (CPM)
- Maximum forward speed at reduced engine rpm

The perfect speed automatically –
no matter what you're doing.



CLAAS HEXASHIFT offers clear benefits.

- Powershift speed adjusts automatically when changing range, depending on load and forward speed
- Good gear spacing in the main operating range
- Fully automatic shifting with HEXACTIV
- Excellent efficiency in the field and on the road for low fuel consumption
- Convenient adjustment options
- High operating comfort with the DRIVESTICK
- Powertrain management for smooth changes in range and powershift operations

HEXASHIFT.
Efficient powershift transmission.

With HEXASHIFT you can shift effortlessly through all six powershift speeds and the four automatic ranges using your fingertips, or you can shift automatically using the HEXACTIV auto-shift function. Overlapping powershift speeds allow you to utilise the full output potential of the engine and provide smooth range shifting on the road.

Always the right speed.

Whether you choose the 40 km/h or the 50 km/h transmission model, the gear spacing in the lower ranges A to C remains the same. This means that you will always have enough ratios available in the main operating range during field work.

HEXASHIFT functions

- The starting gear can be individually set
- Infinitely variable adjustment of the shift points for the automatic powershift
- Adjustable settings for REVERSHIFT clutchless reverser

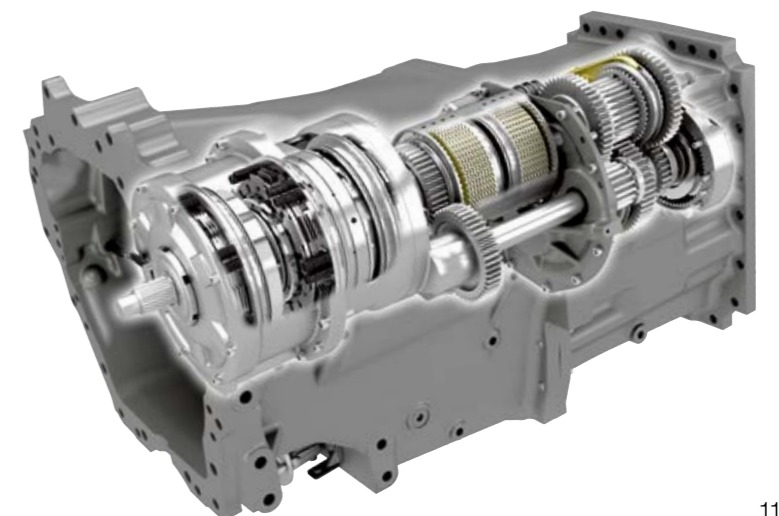

Stable and manoeuvrable. Immense tractive power.

For all applications.

Drawing on experience gained in developing standard tractors to over 400 hp, CLAAS has designed a solution perfectly tailored to the AXION 800 series – for endurance work under extremely challenging conditions.

Fully balanced.

With numerous front and rear axle ballast options, the AXION can easily be adapted to every application. Its full performance potential can then be exploited without unnecessary losses.

If you need to carry out heavy work at low speeds, the ballasting on the AXION can easily be increased. Weight that is no longer required can be removed just as easily.

In practice, this means:

- Maximum stability even when using front-mounted implements
- Large front axle steering angle for maximum manoeuvrability
- Simple weight distribution for maximum tractive power
- Up to 2.05 m diameter tyres for optimal traction



Short overall length:

- Good manoeuvrability
- Short trailer combination on the road
 - Good visibility
- Good guidance of front-mounted implements

Long wheelbase:

- High ride comfort
- Directional stability
 - More tractive power
- Good, safe road handling
 - Max. lift capacity



Ideal weight distribution:

- Reduced fuel consumption
- Low ground pressure during tillage
 - Dynamic road transport
- The right tractive power for every job thanks to easy ballasting



The right connection for every implement.



Pressure-free connections and no mess.

All four hydraulic couplings at the rear of AXION tractors have release levers, so they can be connected and disconnected even under pressure.

The colour-coding on the inlet and outlet sides make it easier to attach implements correctly. Oil leakage lines collect the oil from the couplings when attaching and removing connectors.

AXION 800 – the hydraulics.

- Load-sensing hydraulics with 110 l/min flow or optional 150 l/min flow for applications with a high oil demand
- Up to four mechanical spool valves
- Power Beyond connections at the rear
- CPM provides up to 35 hp boost if hydraulic output falls



Front and rear PTO.

- 540/1,000 rpm as standard
- 540/540 ECO/1,000 rpm optional
- Front PTO (1,000 rpm) optional
- Remote control switch for front and rear PTO shafts
- Automatic PTO engagement/disengagement can be adjusted for lifting heights of different implements on the rear linkage



Ample lift capacity.

A fully integrated front linkage. Factory-fitted too.

When developing the AXION 800, a fully integrated front linkage with up to 5.4 t lift capacity and a front PTO shaft were envisaged from the outset.

Benefits:

- High lift capacity
- Integrated front PTO
- Integrated hydraulic and electric connections
- Two lift capacity options (3.3 and 5.4 t)
- No retrofitting required at the dealer
- Vibration damping

The rear linkage.

The operating layout for the rear hydraulics with 10 t maximum lifting capacity was designed specifically for the AXION 800, and is focused on meeting everyday requirements:

- Draught control
- Position control
- Wheel slip control
- Straightforward operation
- Automatic PTO engagement/disengagement



Spacious and quiet, with large windows and full suspension: thanks to the 4-point cab suspension, cabs on AXION 800 tractors guarantee maximum comfort throughout long working days.

- 320° visibility
- 3 m³ cab volume
- Up to 14 work lights for more comfort
- Well-designed mudguards provide an optimum view of the attached implement
- All the main controls are integrated into the right-hand armrest



Intuitive from the start. Control at your fingertips.

Everything to hand.

The perfectly ergonomic armrest.

The multifunction armrest has been designed for optimum ergonomics, and is the key to relaxed and effective working. It's the result of extensive analyses of the operating processes in the cab: frequently required functions are located on the multifunction armrest, while those required less frequently are located on the right side console.

The unique DRIVESTICK.

The DRIVESTICK handles intuitively and gives full control of the HEXASHIFT transmission. Complex and cumbersome shifting operations are a thing of the past. All you need is nimble fingers to shift as you please.

- 1 Rear linkage operation
- 2 DRIVESTICK for operating the HEXASHIFT
- 3 Hand throttle
- 4 Activation of HEXACTIV automatic transmission and push switch for two stored engine speeds
- 5 Freely assignable function keys
- 6 Rear linkage height adjustment
- 7 Control of up to four spool valves



Greater comfort means higher productivity.

- All the main controls are integrated into the right-hand armrest and can be operated intuitively
- Reliable tractor configuration with the CLAAS INFORMATION SYSTEM (CIS)
- All transmission information is clearly visible on the display in the A-pillar



- Shifting operation, powershift speeds + / -
- Shifting operation, range + / -
- Hold the DRIVESTICK in the first position to continue shifting

Well informed. The CLAAS INFORMATION SYSTEM (CIS).

The CIS display features a compact design and intelligent user ergonomics. All settings can be operated using a rotary switch and the ESC key.

The following functions can be set using the CIS.

- Shift points for the HEXACTIV powershift unit
- Start-up gear for the HEXASHIFT transmission
- Progressivity of the REVERSHIFT clutchless reverser
- Maintenance interval display

The following data can be accessed via the CIS:

- Working width
- Distance covered
- Area worked
- Working time
- Work rate

Ergonomics and comfort for optimum working conditions.

Protects both driver and machine.

No matter how rough the terrain, the AXION 800 ensures that you won't feel a thing. Full four-point cab suspension guarantees maximum ride comfort. And this is just one aspect of a suspension concept which is exemplary in every way.

The driver's seat with pneumatic suspension supports your back even during long working days. Front and rear linkages are vibration-damped.

The 4-point cab suspension.

The cab suspension makes a crucial difference: by effectively absorbing vertical and horizontal vibrations, it ensures that nothing can compromise your driving enjoyment.

The lighting concept turns night into day.

Up to 14 work lights ensure that every nook and cranny is perfectly illuminated. That means you can decide just where to shine a light.



The benefits for you.

- Less stress on the driver
- Higher speed, thanks to cab suspension
- Significant reduction in back and muscle strain
- Good productivity even in the evening and at night
- Logical layout of controls avoids operating errors



Comfort concept.

- Excellent all-round visibility with up to 14 work lights
- Choice of two different suspension seats with extensive scope for adjustment
- Vibration damping on front and rear linkage
- Perfect all-round view
- 4-point cab suspension
- Powerful air conditioning system



Operator assistance systems and data management.

GPS PILOT CEMIS 1200 steers your AXION with absolute precision. It automatically creates reference tracks based on saved field boundaries or a single circuit of the field. The AXION is always aware of its position and switches to the best reference track. Tramlines are displayed in colour and by means of an acoustic signal.

At CLAAS, connectivity is key to improving farming efficiency and precision. You can define reference tracks and create application maps on the office PC. Then use Machine connect to transfer jobs to the tractor. CEMIS 1200 offers seamless communication between machine and office and optimises the application of fertilisers, pesticides and seed. ISOBUS functionalities enable the use of automatic section control, geo-referenced application and standardised task management.



GPS PILOT CEMIS 1200.

Precision farming made easy.

Precise, future-proof, simple.

Improve the profitability of your farm and simplify day-to-day operations – step into the future with the GPS PILOT CEMIS 1200.

With the GPS PILOT automatic steering system, your machine will seem like it's running on rails: always on the right track, using the full working width with no overlapping.

The CEMIS 1200 fits seamlessly into the cab: with the same intuitive control logic as CEBIS, operators will quickly find their way around.

You can use the system on all CLAAS machines set up for GPS PILOT CEMIS 1200. The terminal and receiver can be transferred from one machine to another in next to no time, giving you complete flexibility and saving money.

Thanks to ISOBUS and standard data exchange formats, the CEMIS 1200 is the way forward for more precision in farming.

Reference track planning.

Plan your reference tracks with ease – record reference tracks spontaneously or use reference track management on the CEMIS 1200 to plan your tracks based on field boundaries. Pre-planned reference tracks can also be transferred to the terminal. CEMIS 1200 provides various different drive modes which enable you to maximise the efficiency of your fieldwork.

In addition, tramline management prompts you to create a tramline in the right position. Tramlines are highlighted in colour on the screen, giving you a perfect overview of your work. You can also activate an acoustic signal.

Benefits:

- Intuitive user interface for outstanding ease of use day and night
- Quick access to all important functions
- Freely configurable working areas for custom control
- The fast and easy way to start fieldwork



Reference track management



Tramline management



Cut your costs per hectare
by increasing precision.
steeringsystems.claas.com



Scan me.

Precision guidance.

You need a good correction signal for precise work. It's a given with SATCOR 15¹ as standard for 5 years.

Need even greater accuracy?

Choose the optional SATCOR 3¹ and SATCOR 3 FAST¹ correction signals (± 3 cm).

Absolute precision your top priority?

Choose the GPS PILOT CEMIS 1200 with RTK correction signal for the highest possible repeatable accuracy ($\pm 2-3$ cm).

RTK Bridging.

All RTK correction signals are enhanced by the RTK Bridging function as standard, so if the signal is lost, work can continue for up to 20 minutes with gradually decreasing accuracy.

Difficult topography or mobile phone dead zones in your area?

With RTK Bridging Premium you can carry on working – without loss of accuracy or time limits.

¹ SATCOR 15 / SATCOR 3 / SATCOR 3 FAST powered by Trimble RTX. SATCOR correction signals, RTK Bridging and RTK Bridging Premium are not available in all regions. Together with your CLAAS distributor, we will find the best solution for your individual requirements.

GPS PILOT CEMIS 1200. Moving with the times.

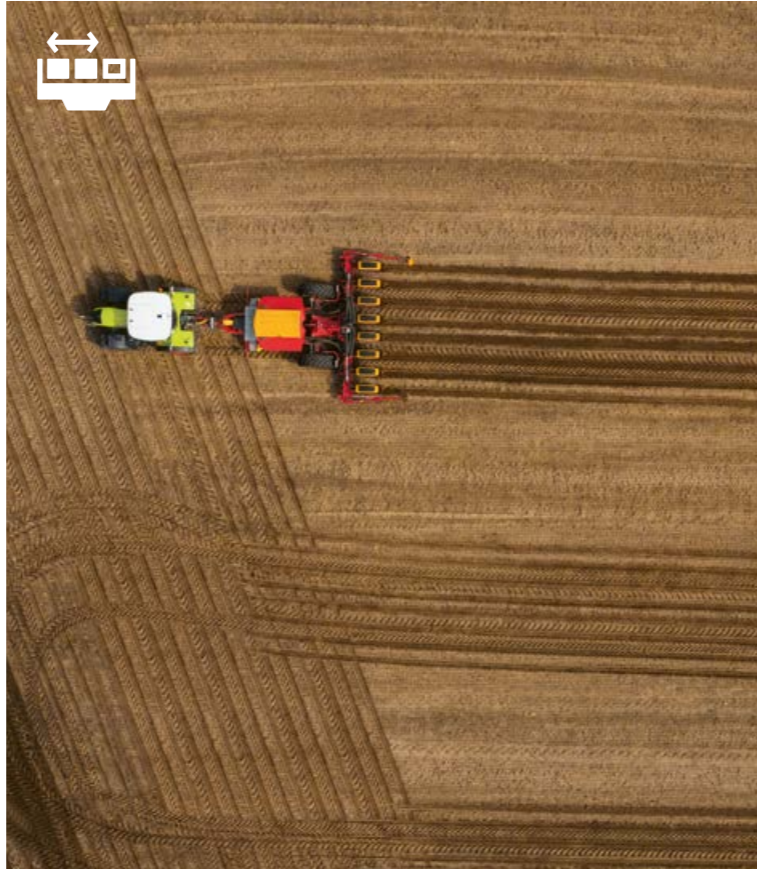

 **Future-proof – GPS PILOT CEMIS 1200.**

With GPS PILOT CEMIS 1200, you get a terminal fit for the future. Tailor-made for your farm, with full functionality pre-installed or added gradually to suit your growing needs.

Still not sure? Why not test additional functions and correction signals free of charge in advance?

Perhaps your requirements have changed during the season? No problem – with the digital connection you can adapt the system's functions quickly and flexibly to suit your needs. The appropriate licence or activation can be transferred online straight to your terminal.¹

 **ISOBUS Universal Terminal (ISO UT).**

The ISO UT implement view can be displayed in the main work screen or in the smaller implement screen. This enables you to customise the display settings to suit your needs. The AUX-N allows functions to be assigned to physical function keys, for example on the CLAAS multifunction control lever.

Benefits:

- Customisable display settings for ISOBUS implements in the CEMIS 1200 terminal
- User-friendly operation using function keys
- Transfer new licences online or activate directly on the terminal

 **ISOBUS TC Section Control.**

The ISOBUS functionality of the CEMIS 1200 allows you to switch sections on or off automatically – for all the precision and none of the hassle.

 **Precision farming and documentation with ISOBUS TC-GEO and VRA.**

With ISOBUS TC-GEO you can easily record geo-referenced data such as application rates. If you want to target applications to specific areas, simply add the VRA (Variable Rate Application) module.

 **Office and machine seamlessly connected. Task management.**

With the CEMIS 1200 and Machine connect, you can handle your job management via your mobile phone connection in just a few clicks – it's standardised and convenient.

Plan your tasks in your farm management software and transfer them straight from CLAAS connect or other connected systems to the machine. The operator has all the tasks in sight and can quickly and easily send them back to the office on completion.

Assign, complete and document – seamlessly and reliably.

¹ in countries with CLAAS connect

A connected tractor is more productive.

Digitalisation pays.

Digitalisation is a key factor in increasing your productivity and efficiency. Data generated in completely different places can be collected and evaluated centrally. This conserves your resources and improves your business processes.

To enable you to get more out of the AXION and your other machines, CLAAS offers a range of modules which allow systems, technology and working processes to be connected with each other, regardless of the manufacturer. Intelligent digitalisation matched to the requirements of your farm can reduce your workload significantly.

- Transfer and document machine and job data quickly
- Manage individual machines and the whole fleet efficiently
- Analyse working processes in detail and optimise them.
- Analyse fields with ease and prepare simple application maps
- Create and manage field track intelligently
- Call up and manage farm data with intelligent farm management software
- Save valuable maintenance and service time with remote diagnostics

NEW: CLAAS connect.

Everything we do revolves around your success, your machines and your farm. And everything you need is now on one platform – CLAAS connect.

With CLAAS connect, all your farm and machine data are clearly arranged in one place. Compare the performance of your machines on the spot to make the most of your fleet's potential. Manage individual service agreements, maintenance notifications, parts catalogues and operating manuals for all your machines. Order parts and consumables straight from your dealer through the integrated shops.

With track planning, you can easily create tracks for efficient fieldwork and manage them on the platform. Instantly create application maps based on satellite maps for precise, targeted application of seed and fertiliser. Send your jobs complete with tracks and application maps straight from CLAAS connect to the CEMIS 1200 terminal to ensure simple, precise execution on the field.

Discover how documentation runs in the background, recording your fieldwork reliably and automatically. Focus on your work and let CLAAS connect take care of the rest.

Need another machine in addition to your AXION? No problem! You can configure one at any time in CLAAS connect and ask your dealer to arrange a demonstration or prepare an offer.

Three Connect packages to make your job easier.

The Connect packages get you on track to manage all your farm's digital tasks. Your CLAAS sales partner and digital specialist will set you up with all the functions you need for your business. Each package gives you a quick overview of your machine and service data in CLAAS connect. The higher level packages help you simplify data exchange between the machine and your office and plan and implement your year-round field work more efficiently.





CLAAS connect links you to your dealer, your machine and your farm.

connect.claas.com

Scan me.

CLAAS connect packages for tractors.

CLAAS connect Package 1	CLAAS connect Package 2	CLAAS connect Package 3
<p>Documentation</p> <ul style="list-style-type: none"> · CLAAS connect · optional: farm licences for CLAAS connect · Machine connect¹ 	<p>Documentation + Steering system</p> <ul style="list-style-type: none"> · CLAAS connect · optional: farm licences for CLAAS connect · Machine connect¹ · GPS PILOT CEMIS 1200 	<p>Documentation + Steering system + Precision Farming</p> <ul style="list-style-type: none"> · CLAAS connect · optional: farm licences for CLAAS connect · Machine connect¹ · GPS PILOT CEMIS 1200 · ISOBUS activations

¹ With an active Machine connect licence (5-year pre-installed licence free of charge), the machine transfers machine and process data to CLAAS connect

Shorter maintenance times. Longer service intervals.



Easy access for fast maintenance.

The AXION 800 clearly comes up trumps in terms of maintenance. The one-piece bonnet allows you easy access to all the main service and maintenance points, and easy exchange of parts. This means that all maintenance operations can be conducted with just a few simple steps.

- Simple oil check
- Easy to top up
- Quick cleaning or replacement of the air filter
- Straightforward cleaning of the cab air filter
- Each radiator is easily accessible
- Good access to the engine oil and diesel oil filter

The benefits for you.

- The CIS on-board information system keeps you up to date with regard to the maintenance status
- You have access to the most important maintenance points
- You can easily carry out simple maintenance tasks yourself
- Long maintenance intervals allow you greater flexibility of operation
- Long-term maintenance also means lower costs

Lower costs, thanks to long maintenance intervals.

The AXION 800 boasts particularly long service intervals. This means that you can get loads of jobs under your belt before having to think about maintenance. The CIS looks after your schedule and notifies you in good time.

The long oil-change intervals (engine 500 h, transmission and hydraulics 1,000 h) save time and money. As a result, less valuable working time is lost during the season and the tractor is where it should be – at work.



Whatever it takes. CLAAS Service & Parts.



CLAAS Service & Parts
is there for you 24/7.
service.claas.com

Scan me.



Safeguard your machine's reliability.

Increase your operating reliability and minimise the risk of breakdown and repair. Machine connect offers you predictable costs. Create your own individual service package to meet your particular requirements.

The availability of products from CLAAS Service & Parts may vary according to country.



Specially matched to your machine.

Precision-manufactured parts, high-quality consumables and useful accessories. Choose our comprehensive product range to be certain of receiving exactly the right solution to ensure 100% operating reliability for your machine.



Global supply.

The CLAAS Parts Logistics Center in Hamm, Germany, stocks almost 200,000 different parts and has a warehouse area of over 183,000 m². This central spare parts warehouse delivers all ORIGINAL parts quickly and reliably all over the world. This means that your local CLAAS partner can supply the right solution for your harvest or your business within a very short time.



Your local CLAAS distributor.

Wherever you are, you can count on us to always provide you with the service and the contact people you need. Your CLAAS partners are on hand in your local area, ready to support you and your machine around the clock. With know-how, experience, commitment and the best technical equipment. Whatever it takes.



Machine connect.

Machine connect provides your service partner with all relevant data from machines equipped with telemetry. This makes remote diagnosis and remote support much easier. Servicing can be carried out more efficiently and machine availability is improved. All you have to do is give your consent.

These outstanding features speak for themselves.



CLAAS POWER SYSTEMS.

- AXION 850 and 820 with rated output of 233 and 189 hp to ECE R 120
- Up to 35 hp reserve power with CLAAS POWER MANAGEMENT
- Intelligent engine technology for economical fuel consumption
- Automatic shifting with HEXACTIV
- 40 or 50 km/h at reduced engine speed
- Matched transmission and rear axle for high efficiency
- Low operating weight reduces fuel consumption on the road
- Long wheelbase and balanced weight distribution for optimal traction
- Up to 5 m diameter tyres for good ground contact
- Up to 400 kg weight per rear wheel transfers more power to the ground
- Fully integrated front linkage and front PTO

Comfort and convenience.

- 4-point cab suspension
- CIS on-board computer for monitoring and adjusting machine settings
- Multifunction armrest
- Convenient speed control with the DRIVESTICK
- Compact length and long wheelbase for easy handling and manoeuvrability
- Air-suspended seat
- Vibration damping for front and rear linkage
- Automatic climate control
- GPS steering
- ISOBUS-ready
- Automatic engagement/disengagement of four-wheel drive, differential and PTO
- GPS PILOT automatic steering and online task management via the CEMIS 1200 terminal
- Good accessibility and long maintenance intervals

AXION		850	820
Dimensions			
Length (with front weights and trailer hitch) (d)	mm	5684	5684
Centre rear axle – cab upper edge (a)	mm	2278	2278
Wheelbase (b)	mm	2985	2985
Distance, rear axle – lower link (c)	mm	1312	1312

Weight			
(standard tyres, with oil and fuel, without driver)			
Weight without ballast	kg	7900	7400
Max. front ballast without front linkage	kg	904	904
Max. permissible gross weight (40 km/h version)	kg	14000	12000
Max. permissible gross weight (50 km/h version)	kg	12000	12000

Ground clearance			
Front axle (e)	mm	587	568
Rear axle (f) (without drawbar)	mm	564	515

AXION		850	820
Tyres			
Rear tyres	Front tyres		
20.8 R 38 (520/85 R 38)	16.9 R 28 (420/85 R 28)	-	□
20.8 R 42 (520/85 R 42)	16.9 R 30 (420/85 R 30)	-	□
580/70 R 42	480/70 R 30	-	□
620/70 R 42	480/70 R 30	□	□
650/65 R 38	540/65 R 28	-	□
650/65 R 42	540/65 R 30	□	□
710/70 R 38	600/65 R 28	□	□
VF 710/60 R 42	VF 600/60 R 30	-	□
650/85 R 38	540/65 R 34	□	-
650/85 R 38	600/70 R 28	□	-
650/85 R 38	600/70 R 30	□	-
VF 650/85 R 38	VF 600/70 R 30	□	-
710/70 R 42	540/65 R 34	□	-
710/70 R 42	600/70 R 28	□	-
710/70 R 42	600/70 R 30	□	-
VF 710/70 R 42	VF 600/70 R 30	□	-

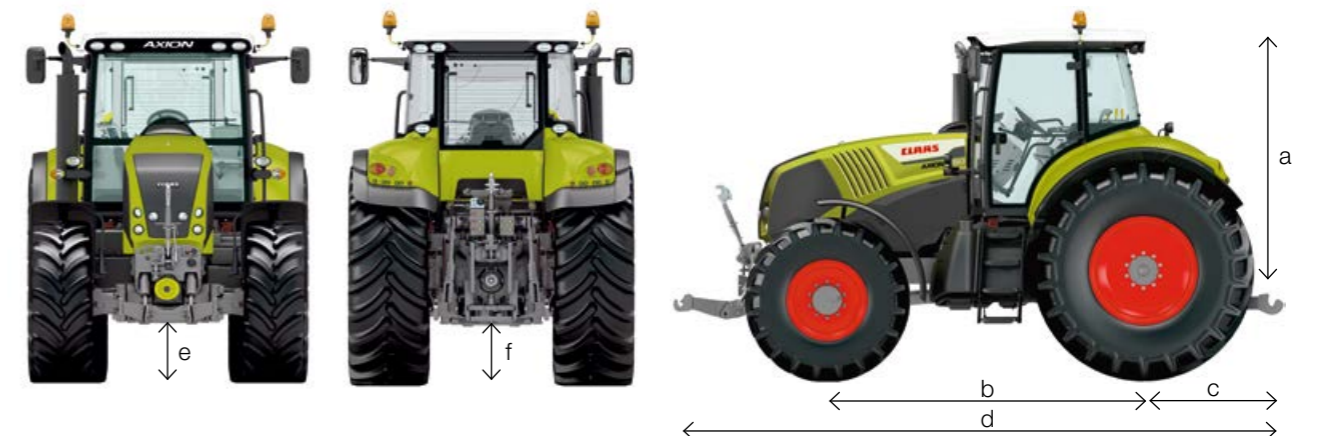

● standard ○ optional □ available - not available

AXION		850	820
Engine			
Manufacturer		DPS	DPS
Number of cylinders / intake		6/TI	6/TI
Cubic capacity	cm ³	6788	6788
Nominal engine speed	rpm	2200	2200
Output at nominal engine speed (ECE R 120) ¹	kW/hp	171/233	139/189
Max. output (ECE R 120) ¹	kW/hp	175/238	145/197
Max. output with CPM (ECE R 120) ¹	kW/hp	197/268	170/232
Output at nominal engine speed (ECE R 24)	kW/hp	165/225	135/183
Max. output (ECE R 24)	kW/hp	169/230	142/193
Max. output with CPM (ECE R 24)	kW/hp	193/260	166/227
Output at nominal engine speed: 97/68/EC ²	kW	187	165
Max. output at engine speed	rpm	2000	2000
Constant output	rpm	400	400
Engine speed at max. torque	rpm	1500	1500
Max. torque	Nm	1020	897
Electronically controlled injection pump		●	●
Air filter dust aspiration		●	●
Fuel tank capacity	l	503	407
Oil-change interval	h	500	500

HEXASHIFT transmission

Ratios F/R		24/24	24/24
Ground speed (min./max.) 40 km/h version	km/h	1.58 / 40	1.72 / 40
REVERSHIFT clutchless reverser		●	●
Powershift speeds		6	6
Electrohydraulically controlled ranges		4	4
HEXACTIV		●	●
Creep range	km/h	0.5	0.5

Rear axle

Electrohydraulically activated differential locks		●	●
Automatic differential locks		●	●
Max. rear tyres		710/60 R 42	710/60 R 42

PTO

Wet multi-disc clutch		●	●
Remote control of engagement and emergency stop		●	●
540/1000		●	●
540/540 ECO/1000		○	○
Changeable PTO stub		●	●
Number of splines		6 / 8 / 20 or 21	6 / 8 / 20 or 21

¹ Approximates ISO TR 14396

² Performance data fit criteria for admissibility. Performance as per 97/68/EC is identical to 2000/25/EC.

● standard ○ optional □ available – not available

AXION		850	820
Four-wheel drive front axle			
Wet multi-disc clutch		●	●
Electrohydraulic operation		●	●
Automatic 4-wheel drive		●	●
Max. steering angle	degrees	55	55
Castor angle	degrees	5	5
Angle of oscillation	degrees	10	10
Turning radius	m	5.19	5.15
Track with tyres	mm	1995 480/70 R 30	1968 16.9 R 28
Pivoting mudguards		○	○

Hydraulics

Load-sensing circuit		●	●
Output at rated speed, standard (option)	l/min	110 (150)	110 (150)
Max. operating pressure	bar	200	200
Number of mechanical spool valves (min.–max.)		3–4	3–4
Flow control		●	●

Rear linkage

Max. lifting capacity at ball ends	kg	10229	9676
Continuous lift capacity at 610 mm	kg	6012	6227
Vibration damping		●	●
25 amp socket		●	●

Front linkage

Lift capacity	kg	3300	3300
Front PTO 1000 rpm		○	○

Cabs

4-point suspension		●	●
Multifunction armrest		●	●
Air conditioning		●	●
Passenger seat		●	●
Cooler compartment		●	●

Data management and operator assistance systems

ISOBUS		○	○
GPS PILOT ready		●	●
GPS PILOT CEMIS 1200		○	○
Machine connect – 5 year licence		●	●

CLAAS continually develops its products to meet customer requirements. This means that all products are subject to change without notice. All descriptions and specifications in this brochure should be considered approximate and may include optional equipment that is not part of the standard specifications. This brochure is designed for worldwide use. Please refer to your nearest CLAAS dealer and their price list for local specification details. Some protective panels may have been removed for photographic purposes in order to present the function clearly. To avoid any risk of danger, never remove these protective panels yourself. In this respect, please refer to the relevant instructions in the operator's manual.

All technical specifications relating to engines are based on the European emission regulation standards: Stage. Any reference to the Tier standards in this document is intended solely for information purposes and ease of understanding. It does not imply approval for regions in which emissions are regulated by Tier.

● standard ○ optional □ available – not available

We want to make you the best in your field.

In everything we do, the focus is on you, our customers. We understand your daily challenges. Together with you, we develop agricultural technology ensuring you can farm successfully and sustainably today and in the future. Our digital solutions simplify complex processes and make your work so much more convenient.



CLAAS KGaA mbH
Mühlenwinkel 1
33428 Harsewinkel
Deutschland
Tel. +49 5247 12-0
claas.com