



Square balers

## QUADRANT EVOLUTION

5300 5200 4200





When reliability matters –  
the QUADRANT from CLAAS.



<b>QUADRANT from CLAAS</b>	<b>2</b>
Globally recognised	4
Model overview	6
<b>The technology</b>	<b>10</b>
Tying, reliability	12
Comfort, performance	14
Attachment	16
Pick-up	18
POWER FEEDING SYSTEM (PFS)	20
Hydraulic feeder unit	22
ROTO FEED	26
ROTO CUT	28
FINE CUT	30
Knife drawer	32
SPECIAL CUT	34
<b>Prechamber, packer, bale chamber</b>	<b>38</b>
Adjustable prechamber and packer	40
Drive system and interactive safety	42
Automatic baling pressure control	44
Bale chamber	46
Axles and tyres	48
<b>Tying</b>	<b>50</b>
CLAAS knotter	52
CLAAS knotting technology	54
Bale weighing system	56
<b>Machine operation</b>	<b>58</b>
<b>CLAAS Service &amp; Parts</b>	<b>62</b>
<b>Maintenance</b>	<b>64</b>
<b>Specifications</b>	<b>66</b>



**51 knives**

FINE CUT (5300 / 5200 / 4200) delivers 36,000 cuts per minute during bale preparation – thanks to 51 knives. Ideal for mixer wagons, poultry and livestock kept on slatted floors.



**250-1250 kg bale weigher**

Four sensors allow the bale to be weighed extremely accurately, right on the bale ramp.



**Six CLAAS knotters since 1921**

Patented in 1921: the high-performance single knotter with eccentric needle control – reliable knotting with no twine residue.



**Maximum convenience**

Tried and tested automatic baling pressure control – for optimal baling pressure, unsurpassed bale quality and maximum operator comfort.



Quality speaks for itself – in any language.



“The new APC 2.0 baling pressure control simply provides even finer control,” says contractor Albert Steyns from Lontzen, Belgium. “This is certainly important with straw, but the big league is wet grass silage. My customers were thrilled, because their bales felt like bricks. The new baling

pressure control system has really delivered genuine progress.”



“With its hydraulic prechamber, the QUADRANT is even more versatile. It produces well-formed bales even in the most difficult conditions.”

Daniel Cosson, Contractor, Bezange-la-Petite, France



“The baler works perfectly and cuts cleanly, and the bales are very densely compressed and have a high weight.”

Hendrik Mennega, Eext, Netherlands



“The terminal is pretty easy to use. The menus are well laid out and it’s easy to change settings.”

Quentin Royer, Marne, France



“The TURBO FAN cleans the knottter units from different sides and keeps them completely clean.”

Attila Balász, Oszkó, Hungary



“This machine simply works more cleanly,” Sandro Schwer raves about the new 5-row HD pick-up on the QUADRANT 5200 FC. “We’ve produced 7,000 bales with it,” adds Oskar Schwer. “The new pick-up comes into its own in heavy, wet grass, above all. Thanks to its aggressivity, it picks up even wet crops really cleanly.”

In addition to the improved crop intake, the two professionals from Königsfeld in the Black Forest love the new chain lubrication above all. “In the winter months, we always maintain our machines proactively,” they report. “We can’t afford breakdowns during summer. The new chain lubrication ensures that the PU chains are always well lubricated. We expect a longer service life as a result – something the new chain tensioner will also contribute to.”



## Three straightforward workhorses with a penchant for clean edges.

### High throughput in all conditions.

- The automatic baling pressure control ensures particularly high, even bale density.
- The high rotor speed combined with the unique Power Feeding System (PFS) guarantees excellent crop flow.
- The knife drawer and cutting frame can be lowered in all QUADRANT models with knife bank.
- The baler works without disruption thanks to smart safety technology.
- The 5-row HD pick-up is controlled on both sides and rakes particularly efficiently.
- The TURBO FAN II knotter cleaning system boasts a 145-km/h air flow and active air guidance.

- The hydraulically driven POWER FEEDING SYSTEM (PFS) can be adjusted in speed and conveniently reversed (as an option).
- With the integrated bale weighing system, the weight of each bale can be retrieved and processed anywhere via TELEMATICS.

#### Hydraulic feeder unit.

A hydraulically driven POWER FEEDING SYSTEM (PFS) is available for the QUADRANT 5300, 5200 and 4200. The PFS can be adjusted in both direction and speed to allow the crop flow to be flexibly adapted to the given conditions and optimised.

## QUADRANT 5300 EVOLUTION. The baling heavyweight.

For a bale size of 1.20 x 0.90 m.

Output/throughput

Density

Convenience

#### Individual strengths:

- 46 ram strokes per minute for good throughput and excellent bale density
- Hydraulically controlled prechamber for optimal bale weight, depending on crop volume
- FINE CUT with 51 knives for outstanding cutting quality
- Eccentric needle control
- 3.85-m-long bale chamber

## QUADRANT 5200 EVOLUTION. The workhorse.

For a bale size of 1.20 m x 0.70 m.

Output/throughput

Density

Convenience

#### Individual strengths:

- 56 ram strokes per minute for good throughput and excellent bale density
- Hydraulically controlled prechamber for optimal bale weight, depending on crop volume
- FINE CUT with 51 knives for outstanding cutting quality
- 3.85-m-long bale chamber

## QUADRANT 4200 EVOLUTION. The entry-level model.

For a bale size of 1.20 m x 0.70 m.

Output/throughput

Density

Convenience

#### Individual strengths:

- 51 ram strokes per minute for good throughput and excellent bale density
- Automatic three-phase prechamber for optimal bale density
- Drawer system for ROTO CUT with 25 knives and knife group activation and FINE CUT with up to 51 knives
- 3.45-m-long bale chamber

QUADRANT	5300	5200	4200
1 Bale size 1.20 x 0.90 m	●	-	-
2 Bale size 1.20 x 0.70 m	-	●	●
3 Pick-up width 2.35 m	●	●	●
4 2 oscillating pick-up castor guide wheels	●	●	●
5 Hydraulically driven POWER FEEDING SYSTEM (PFS)	○	○	○
6 2 cam tracks and 5 rows of tines	□	□	□
7 ROTO FEED	□	□	□
8 ROTO CUT (25 knives)	□	□	□
9 FINE CUT (51 knives)	□	□	□
10 Knife drawer	●	●	□
11 Adjustable hydraulic prechamber	●	●	-
12 Fixed-cycle prechamber	-	-	-
13 46 ram strokes	●	-	-
14 51 ram strokes	-	●	-
15 56 ram strokes	-	●	-
16 Automatic baling pressure control	●	●	○
17 ISOBUS-compatible	●	●	●
18 Automatic electric central lubrication system	●	●	○
19 6 CLAAS HD single knotters without twine residue	●	●	●
20 Knotter monitoring	○	○	○
21 TURBO FAN knotter cleaning system with air diffuser	●	●	●
22 Eccentric needle control	●	-	-
23 LED package	□	□	-
24 Bale weighing system	○	○	○
25 Bale ramp can be folded via the terminal	○	○	○
26 Baling for front-mounted choppers	○	○	-
27 2 additional twine boxes for 6 reels each	○	○	-

● Standard ○ Optional □ Available - Unavailable





# What makes forces most effective? When they work together.

## Four factors for successful harvesting.

We understand precisely how important perfect synergy is throughout the harvesting process. That's why we bring together all our technical knowledge and experience in one of the world's largest state-of-the-art development centres for baling technology. This is where our latest development was designed: the QUADRANT EVOLUTION. This powerful square baler sets new benchmarks in terms of tying, reliability, comfort and performance – that is everything that supports you in working more productively.



QUADRANT	5300 EVOLUTION	5200 EVOLUTION	4200 EVOLUTION
Bale dimensions, cm	120 x 90	120 x 70	120 x 70
FINE CUT knife bank, knife option 1	0, 12, 13, 26, 51	0, 12, 13, 26, 51	0, 12, 13, 26, 51
FINE CUT knife bank, knife option 2	0, 13, 25, 26, 51	0, 13, 25, 26, 51	
Knife drawer	●	●	●
Maximum tyres	620/50 R 22.5		
APC	●	●	○
Weighing system	○	○	○
Hydraulically driven PFS	○	○	—

● Standard ○ Optional — Unavailable





## Proven tying.

For more than three decades, CLAAS has been leading in the square baler segment. The CLAAS loop knotter produces knots that are 20% firmer than those of any double knotter, and as always it works without leaving twine residue.

### Economical and safe.

- The CLAAS loop knotter produces knots that are 20% firmer.
- By avoiding twine residue, you save up to 0.5 m twine per bale.
- The fold-down twine guide makes initial threading even more convenient.
- The twine brake is quick to adjust and can be matched to the twine without tools.
- A built-in water tank is provided for convenient hand washing.
- Automotive seals keep the twine box dust-free.
- Additional twine boxes allow more twine reels to be stored (6 reels on each side).

100 years of knotter competence and 20% firmer knots.  
**Page 42**

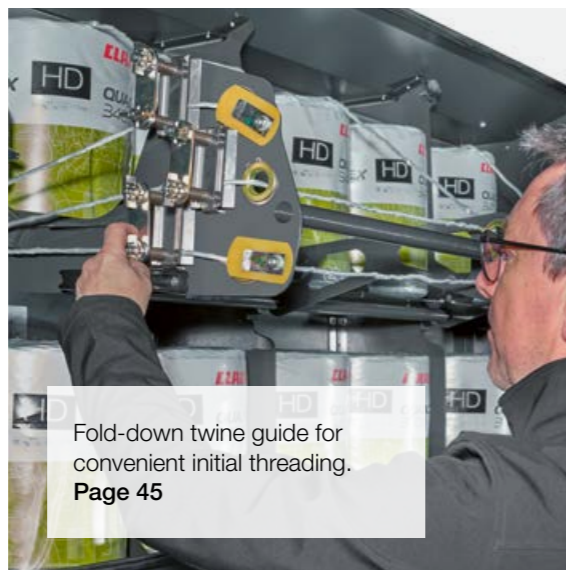
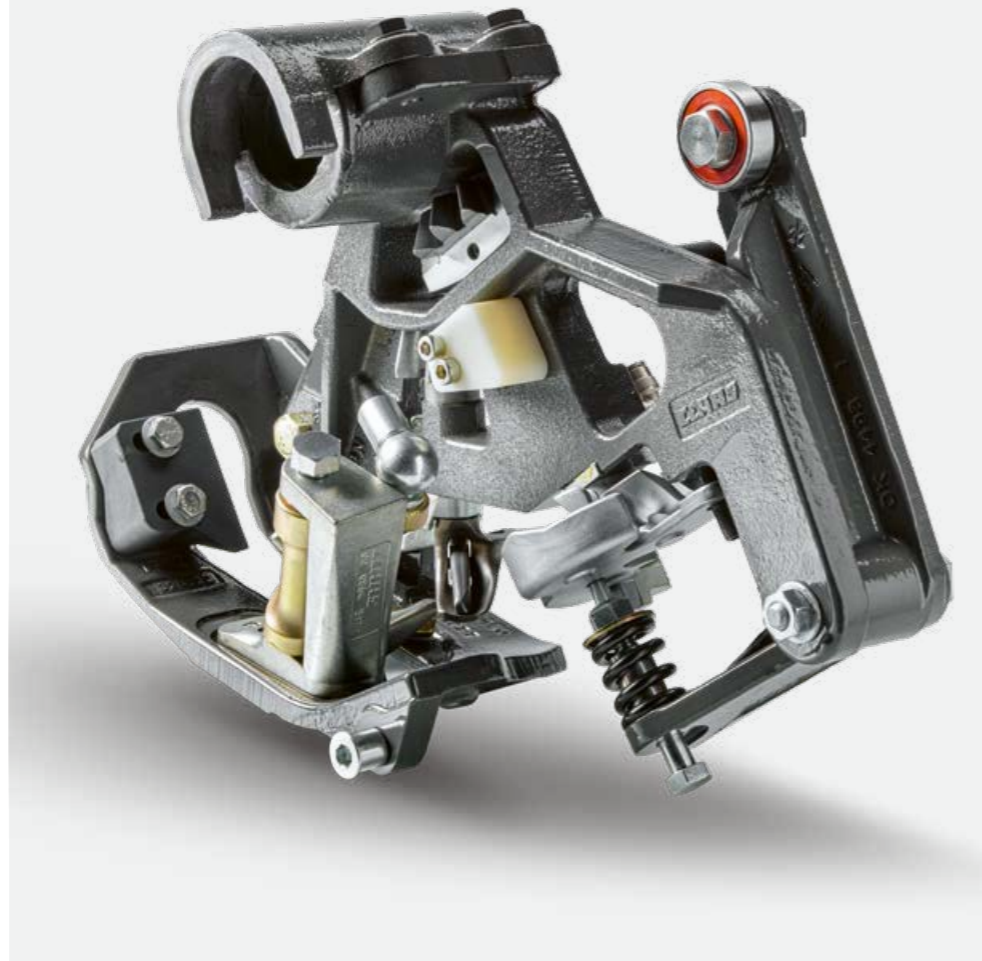

Fold-down twine guide for convenient initial threading.  
**Page 45**



Safe, clean knots without twine residue.  
**Page 44**



Heavy-duty piston track rollers with up to five times longer-lasting ball bearings.  
**Page 41**



Permanent chain lubrication for greater operational reliability and lower maintenance costs.  
**Page 56**

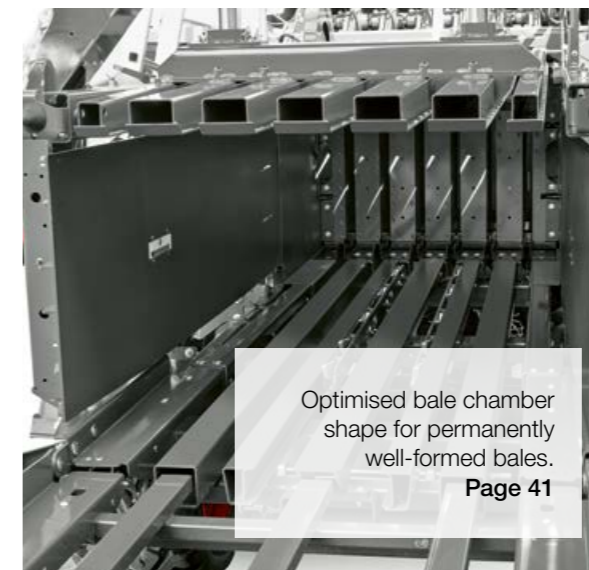

Optimised bale chamber shape for permanently well-formed bales.  
**Page 41**



## Reassuring reliability.

The main tube, the tine bar and the two cam tracks are designed for very long runtimes. The rotor and packer clutches communicate with each other. The machine is always 100% synchronised.

### Durable and highly robust.

- The HD piston track rollers run on automatically lubricated ball bearings that last up to five times longer and do not need to be replaced.
- The HD baling pistons with high-quality S700 wear segments are particularly robust.
- A total of five different HD kits are available for tough special applications in maize straw or sugar cane.





Relaxed comfort.

The QUADRANT supports you with a high level of comfort in all operations. Work with ease to produce perfectly pressed bales with particularly highly compacted edges for greater transport and storage stability.

Convenient and productive.

- Operate the bale ramp and bale ejector conveniently from the driver's seat (optional).
- A PROFICAM is mounted on the bale chamber to provide an uninterrupted view of the bales.
- The camera image can be displayed either on a separate monitor or via the new CEMIS 700.
- The 7" CEMIS 700 is intuitive to operate via a touchscreen, keys or a rotary pushbutton.
- TELEMATICS ON IMPLEMENT (TONI) automatically transfers all key baler data to the cloud.



Flywheel with more external weight for added comfort.  
Page 43



The CEMIS 700 gives easy access to all key functions directly from the driver's seat.  
Page 52

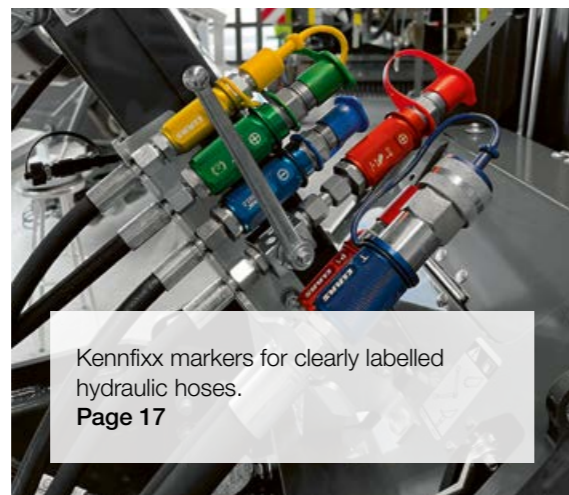

Kennfixx markers for clearly labelled hydraulic hoses.  
Page 17

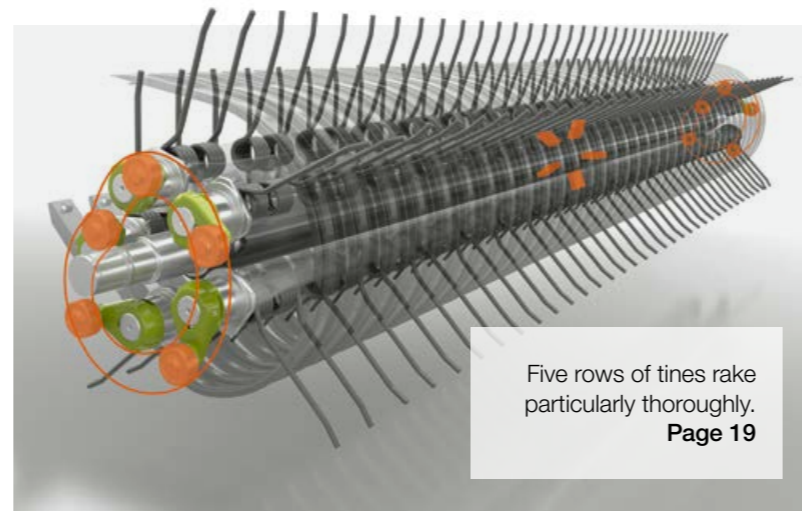

Five rows of tines rake particularly thoroughly.  
Page 19



Up to 56 piston strokes per minute make the QUADRANT EVOLUTION the fastest baler on the market.  
Page 8

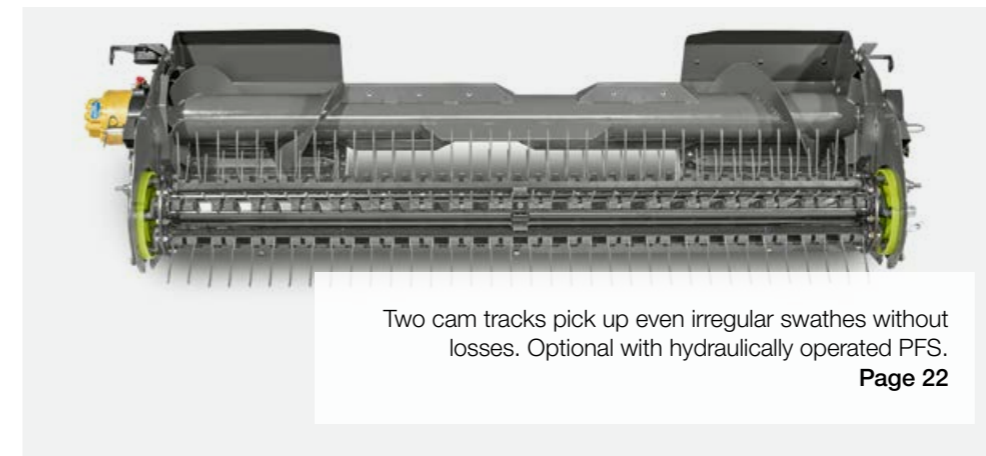

Two cam tracks pick up even irregular swathes without losses. Optional with hydraulically operated PFS.  
Page 22



APC automatic baling pressure control with fast-acting sensors.  
Page 39



Top performance.

The POWER FEEDING SYSTEM (PFS) operates at a 10% higher speed. The pick-up, PFS and rotor speeds are matched to each other. Your advantage: evenly compacted, rock-hard bales with hard edges in any swathing conditions.

High throughput, thorough work.

- The pick-up runs particularly smoothly thanks to cam track control on both sides.
- The separate protection of the pick-up and PFS boosts performance.
- The optimised top bale chamber plate ensures rock-hard bales right to the edges.
- Continuous straight bale chamber plates compact the bales more evenly.
- The closed bale chamber design guarantees particularly square bales, right through to the edges.
- FINE CUT technology with 51 knives delivers optimal cutting quality.



Even very heavy workers should be easy to hitch.

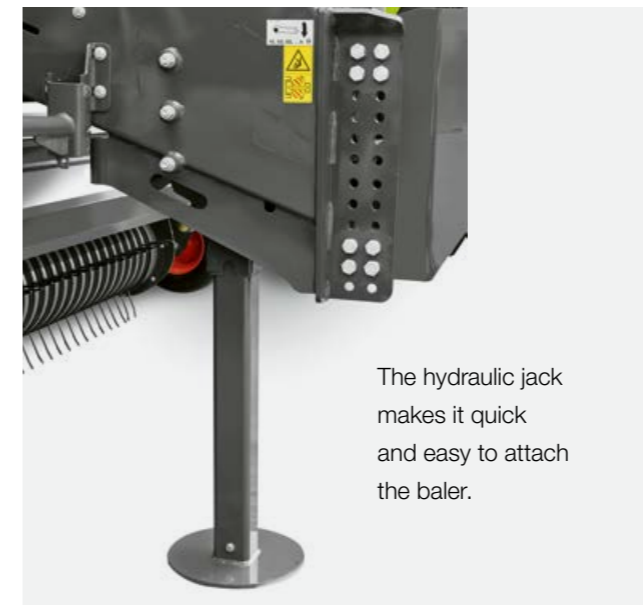

The hydraulic jack makes it quick and easy to attach the baler.

#### Continuous stand.

The hydraulic jack leaves nothing to be desired. It is conveniently controlled via a direct connection and features an extra-large support plate to ensure stable support even on uneven ground.



#### Clear Kennfixx marking.

Driving a QUADRANT means operator comfort in a class of its own. So does hitching a QUADRANT. Thanks to hydraulic hoses with Kennfixx markers as standard, hose functions are clearly labelled and can be easily identified even after years of use. The quick-release coupling system is also optionally available as a flat-face version. This makes attaching the baler even easier and minimises operating errors.

#### At a glance.

- Adjustable, heavy-duty drawbar with versatile hitching options for all tractor types
- Quick coupling of hydraulic hoses thanks to Kennfixx markers
- Hydraulic jack for convenient hitching
- Hydraulically folding castor guide wheels for comfort and safety on the road



#### Safety on the road.

To transport the QUADRANT on public roads, you do not need to remove the castor guide wheels, just fold them in.



Every blade is worth harvesting – no matter how small it is.

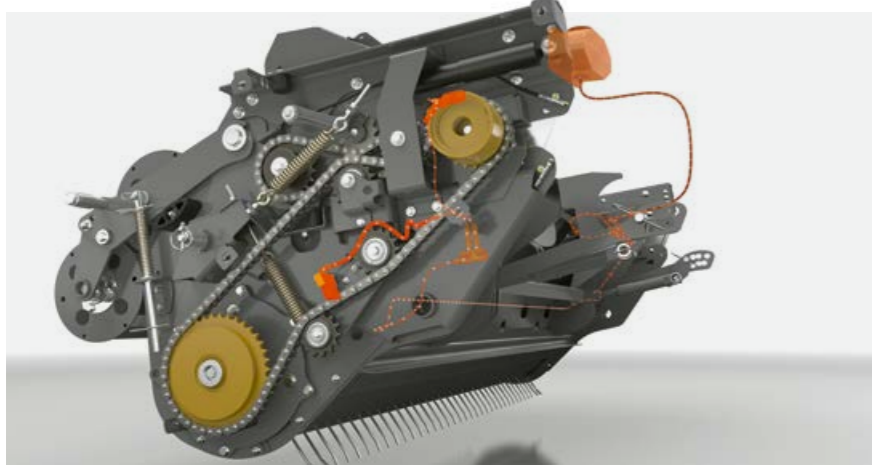
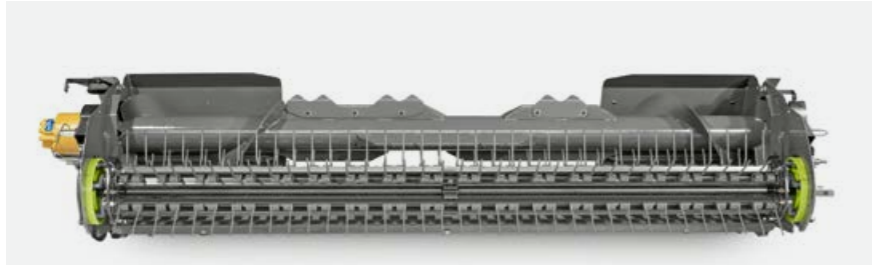

With a 7.2-l oil reservoir volume, the automatic, permanent chain lubrication ensures reliable operation on long working days and a long service life. The oil quantity can be adjusted independently of the operating conditions.

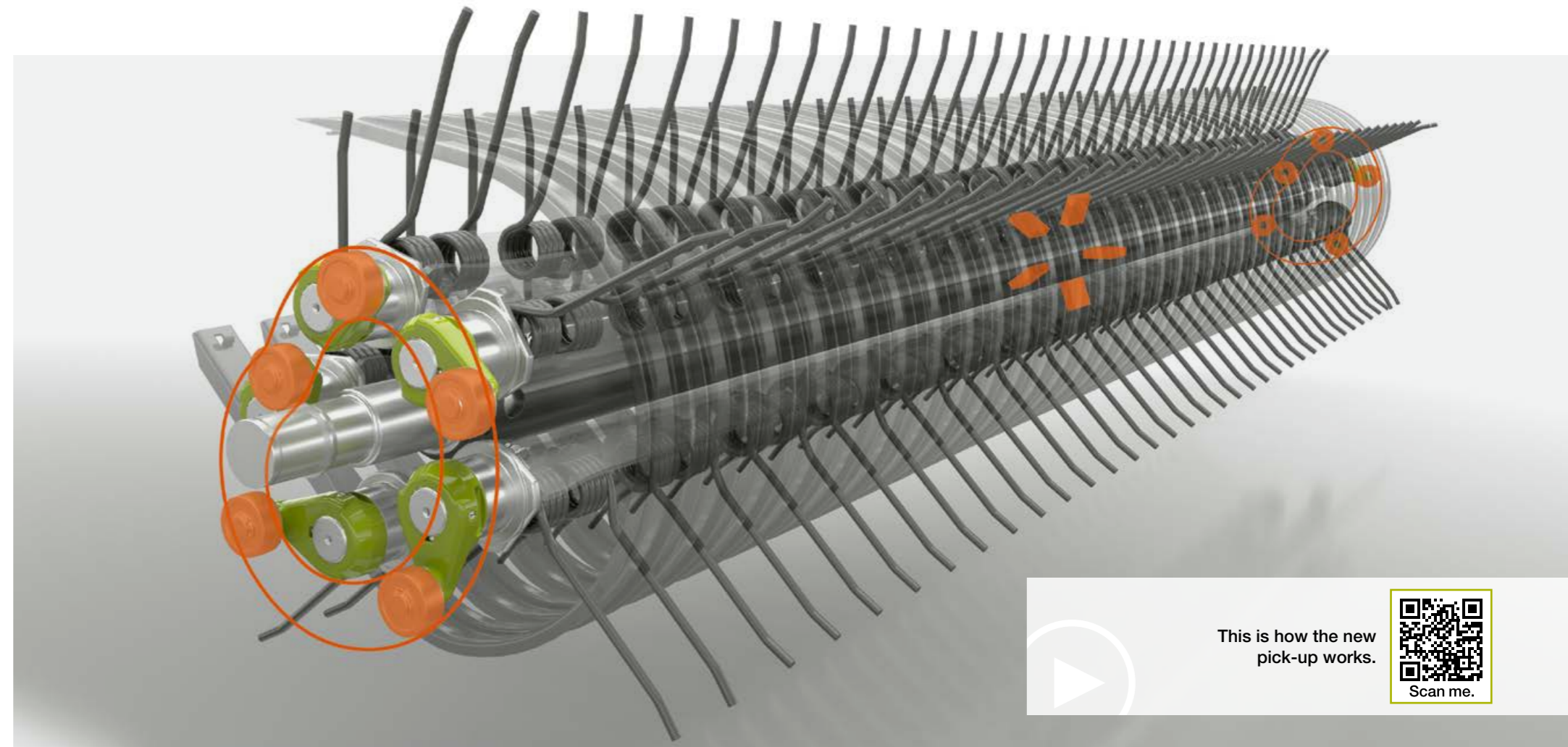

This is how the new pick-up works.



#### At a glance.

- Clean feed intake in any conditions thanks to the optimally fine-tuned interaction between the double roller crop press, pick-up, PFS and rotor
- 10% faster speed on PFS
- Proven robust body from the 5-row JAGUAR pick-up
- Double-sided cam track control (JAGUAR components)
- Permanent lubrication of the pick-up chains with 7.2-l oil reservoir

#### Five tine bars for high loads.

Five rows of tines, ideally spaced for thorough raking, guarantee superior results on the field and pick up a lot of forage. The twin spring steel tines are bolted firmly to five rugged tine bars to withstand continuous and extreme loads. The crop is funnelled to the appropriate width for entering the bale chamber via the two intake augers on either side of the wide pick-up mechanism (ROTO FEED) or via the continuous POWER FEEDING SYSTEM (PFS) roller. This produces firm bales that are highly compacted at the edges for excellent stability during transport and storage.

#### Loss-free, smooth-running intake.

The controlled tines run in two cam tracks, which means they pick up even irregular swaths without losses and move the crop close to the rotor. The pick-up always remains clean. This is ideal for maximum throughputs of a wide range of crops. With the new pick-up you additionally benefit from very smooth operation and less wear.

#### Pick-up control on both sides.

You always have a clear view of the pick-up from the tractor cab. As a result, you can adjust your ground and baling speeds quickly to harvest conditions and bale continuously at high throughputs.

- Rapid, loss-free pick-up even of irregular swaths thanks to pick-up control on both sides
- Shock absorption by means of pressure accumulator suspension

- Suspended castor guide wheels for optimal ground contour following and protection of the grass cover, including at high ground speeds and when cornering
- Patented roller crop press for accelerating the crop flow in all QUADRANT models
- Short distance between the pick-up and rotor or packer for rapid crop transfer and high throughput



We simply can't get enough.



### Transverse feed auger.

The continuous transverse feed auger, cushioned by shock absorbers and with large pitch and aggressive paddles, delivers the harvested crop far down into the rotor. In the process, the crop flow is effectively evened out and accelerated in its delivery to the rotor.

### POWER FEEDING SYSTEM (PFS).

The wider stars reduce the distance to the knife, further enhance the cutting quality, and give maximum durability and working life. The unique combination of roller crop press and actively powered, continuous-feed intake auger makes your work easier.

The QUADRANT can even process large uneven swaths.

- Capacity for high per-hour throughput
- Achievement of high forward speeds
- Crop flow homogenised and accelerated
- Suitable for all swaths
- High throughput, thanks to 20 percent increased protection from the PFS slipping clutch
- Adjustable wear bars for longer pick-up service life and better adaptation to any kind of crop

### At a glance.

- The continuous transverse feed auger, cushioned by shock absorbers, evens out and accelerates the crop flow.
- The QUADRANT boasts an impressive intake capacity even with large, irregular swaths.
- The new POWER FEEDING SYSTEM (PFS) delivers a 10% higher speed so you can bale faster and more evenly.

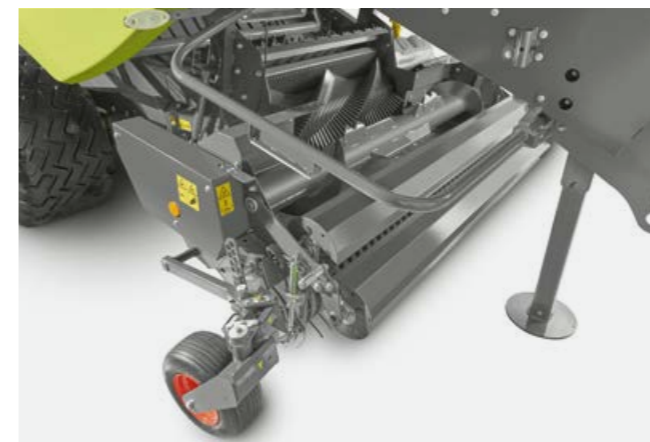



Our intake capacity just keeps on growing.

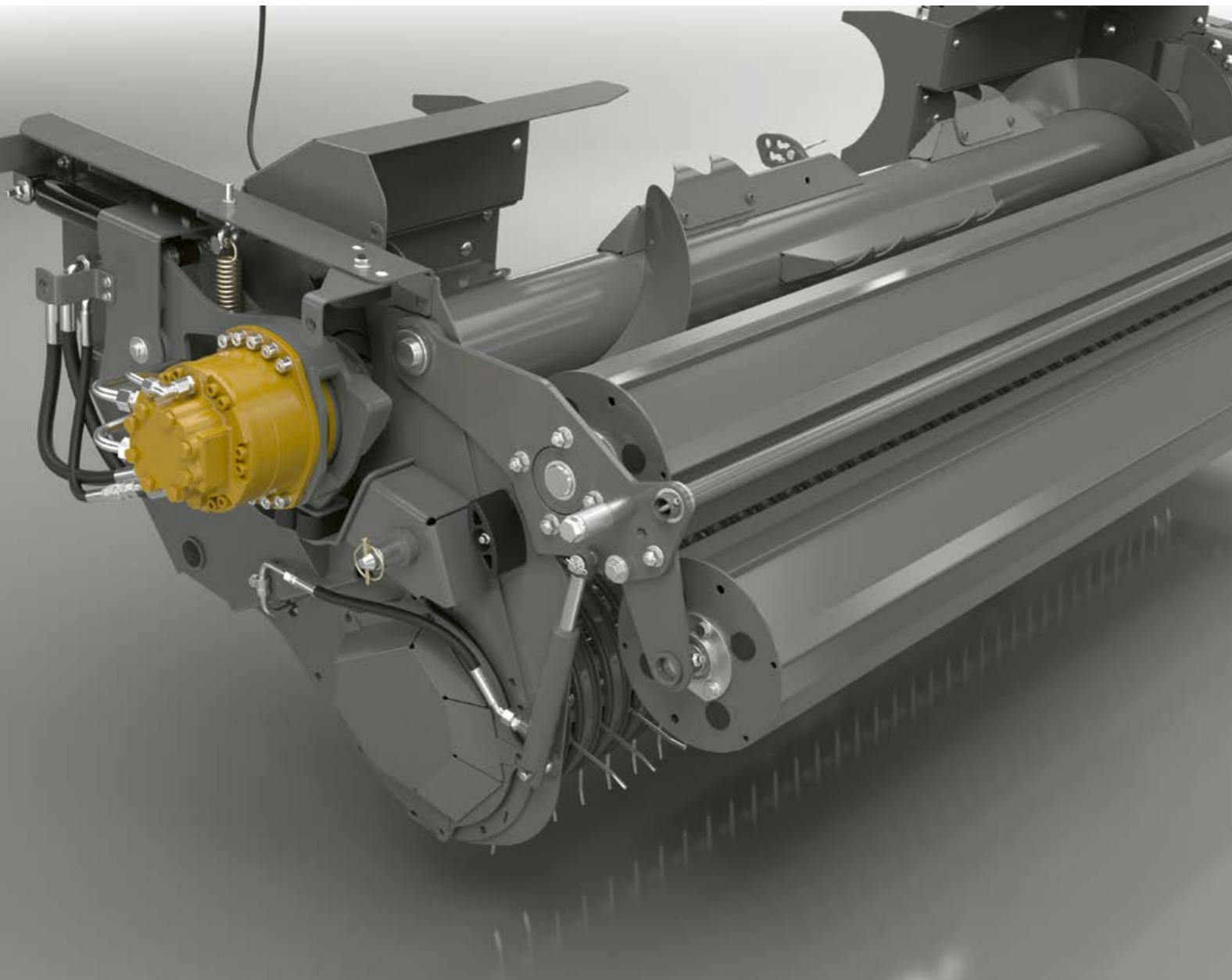

Pick-up, PFS and roller crop press ensure an optimum crop flow.



The hydraulic PFS intake is easy to adjust from the tractor seat.



The POWER FEEDING SYSTEM is easily reversed from the driver's cab.

### Hydraulic feeder unit.

CLAAS offers a hydraulically driven intake for the QUADRANT 5300, 5200 and 4200.

The benefits of a hydraulic feed system are clear to see:

- Individual adjustment to harvest crop conditions for greater forage protection
- Greater adaptability to field conditions
- Optimised crop flow
- Reverse control from the cab, for maximum user-friendliness

The hydraulic drive enables the driver to adjust and optimise the crop flow according to the conditions.

With most crops, it is important that the crop is taken in as quickly as possible to ensure optimal crop flow. However, lucerne, for example, must be handled particularly gently. The hydraulic intake allows drivers to adjust operations correspondingly so that they can directly improve forage quality.

### Variable speed adjustment.

Variable speed adjustment allows rotor filling to be optimised via the POWER FEEDING SYSTEM (PFS). The hydraulic PFS is more flexible than the mechanical version and is better able to handle a variety of different crops.

### Convenient reversing option controlled from the driver's seat.

The driver can also clear any blockages via the control terminal, from the comfort of the driver's seat. This makes the task easier and less stressful.

### At a glance.

- Convenient, gentle on forage and flexible: the hydraulically controlled intake
- Variable speed adjustment
- High comfort: easy reversing option via the operating terminal

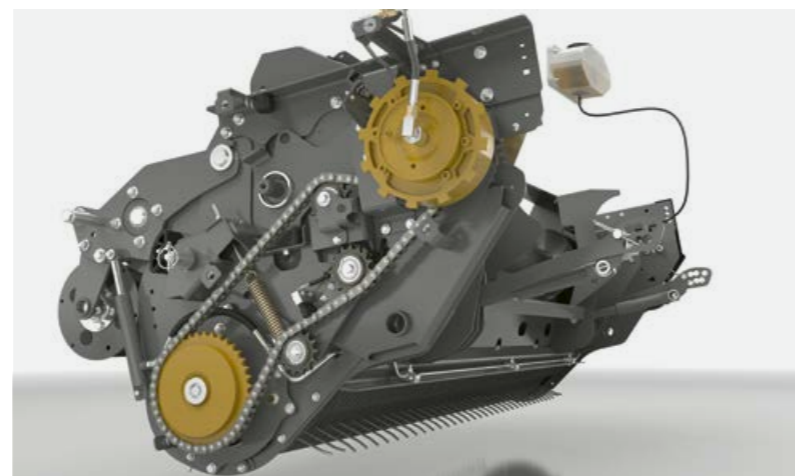

Discover the pick-up's special features.





# The baling heavyweight. QUADRANT EVOLUTION.

One thing is important to us: your harvest success. With our square balers, we provide you with reliable work horses on the field – with vast throughput, unique bale density and outstanding cutting quality. The QUADRANT EVOLUTION models combine advanced systems with a high level of operating comfort – from the intake to the finished square bale.





Sometimes a gentle touch is called for.



ROTO FEED – rotor technology with no cutting required.

QUADRANT stands for continuous rotating intake even without the cutting system. The high rotation speed ensures an outstanding throughput and high area outputs. Thanks to a uniform intake and active delivery to the prechamber, the QUADRANT produces sharp-edged, evenly proportioned and perfectly compacted bales.

High dead weight.

The high dead weight of the rotor keeps the mechanism running extremely smoothly. Owing to the rotor's large mass, the rotor speed remains constant even in uneven swaths, reducing the load transmitted to the tractor drive.

Innovative arrangement of rotor blades protects the crop.

The large 500-mm diameter rotor and the spiral-shaped arrangement of the four-arm rotor blades protect the crop extremely well:

- Uniform intake
- High throughput
- Low power requirement and low dust accumulation
- Suitability for delicate forage types such as lucerne
- High standard of crop protection and excellent forage quality, thanks to the innovative arrangement of the rotor blades
- POWER FEEDING SYSTEM (PFS) available in all models

At a glance.

- Outstanding throughput and high area outputs: ROTO FEED with feed rotor
- High rotor weight for smooth running
- Innovative arrangement of rotor blades helps protect delicate crops such as lucerne

QUADRANT		5300	5200	4200
ROTO FEED		□	□	□
Diameter	m	0.5	0.5	0.5
Width	m	1.2	1.2	1.2

□ Available – Unavailable



One of the benefits of tasty silage is an increase in your milk yield.

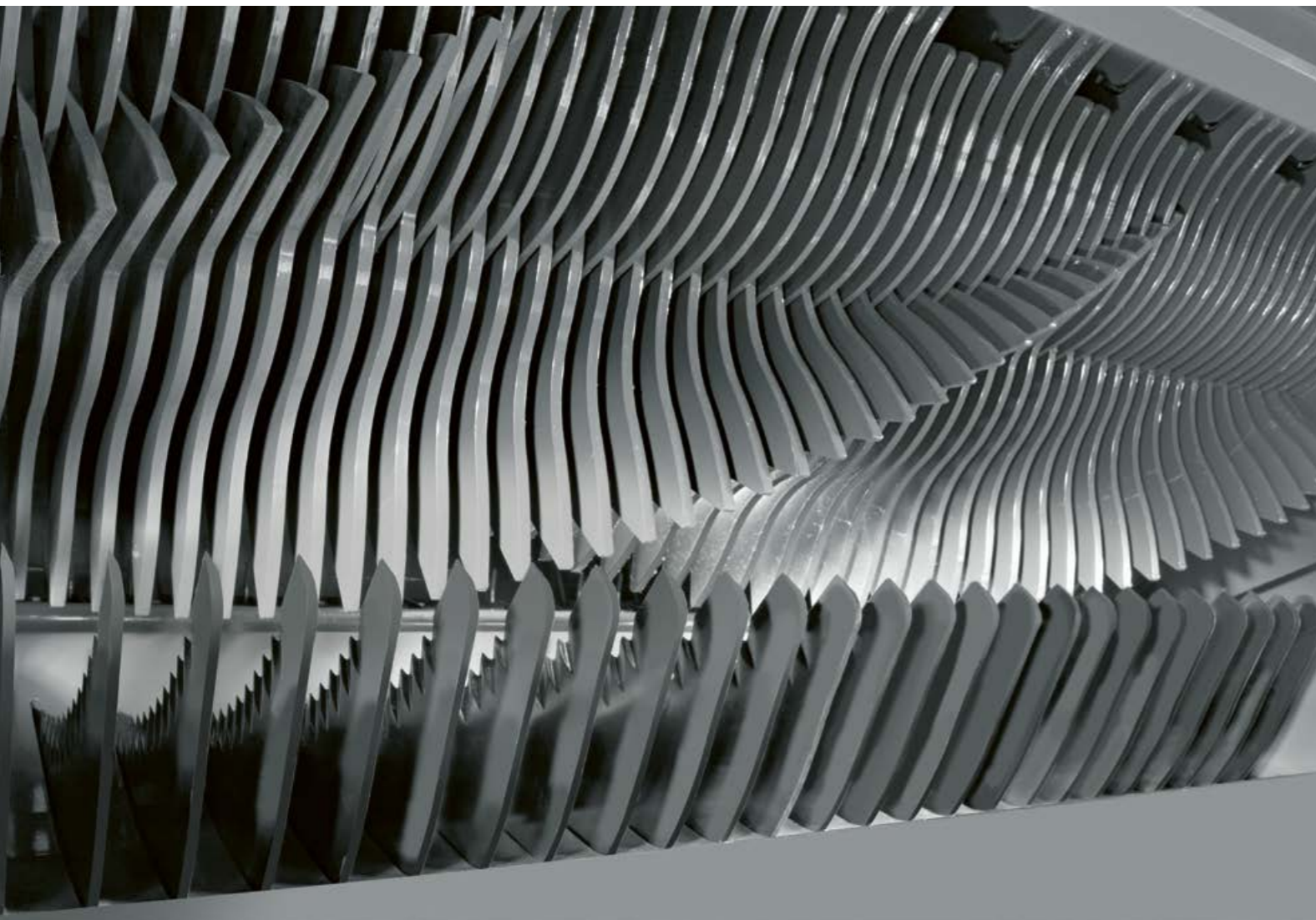

Optimal silage quality with ROTO CUT.

Energy-rich and tasty silage with proper lactic acid fermentation is crucial for high milk production in the dairy herd. The three essential ingredients are a short length of cut, high baling pressure and the exclusion of oxygen. With 18,000 cuts per minute, the CLAAS ROTO CUT is currently one of the systems with the highest cutting frequency on the market, enabling lengths of cut of 45 mm with excellent cutting quality.

Benefits of ROTO CUT: more cuts per minute.

- Less time spent mixing in the feed mixer
- Better forage quality
- Less feed residue

Knife group activation allows you to react flexibly to the requirements of the job at hand. The knife groups can be pre-selected on the machine and extended or retracted via the control terminal.

The complete cutting system at a glance:

- Massive 25-knife cutting rotor made of double-hardened boron steel
- Four rows of tines for optimum crop intake
- Aggressive knives with extremely long blades for especially good cutting quality
- Precise knife guidance through the spirally arranged dual tines
- Individual blade protection
- Flat, power-saving cutting angle

25 knives for top forage quality.

The 25-knife cutting rotor works precisely, quickly and efficiently, ensuring a top-quality feed product. Since the crop is cut short and precisely into small lengths, it can be compacted more densely and later broken down much more easily.

Safe and secure: the hydraulic cutting frame.

Two hydraulic knife guards with pressure relief valve ensure that you do not overload the QUADRANT in the event of a blockage. The cutting frame is lowered hydraulically and allows the rotor to start up again independently. Moreover, the lowerable floor makes it easy to clear blockages from the cab.

At a glance.

- Top silage quality with optimal lactic acid fermentation, thanks to ROTO CUT
- Greater compaction and easier breakdown of the silage
- Controllable knife group activation with the right knife for every application
- Fewer blockages, thanks to the hydraulic cutting frame



QUADRANT	5300	5200	4200
Number of tine rows	4	4	4
Knife group activation	25, 13, 12, 6, 0	25, 13, 12, 6, 0	25, 13, 12, 6, 0
Drop floor	Automatic	Automatic	Automatic

□ Available - Unavailable



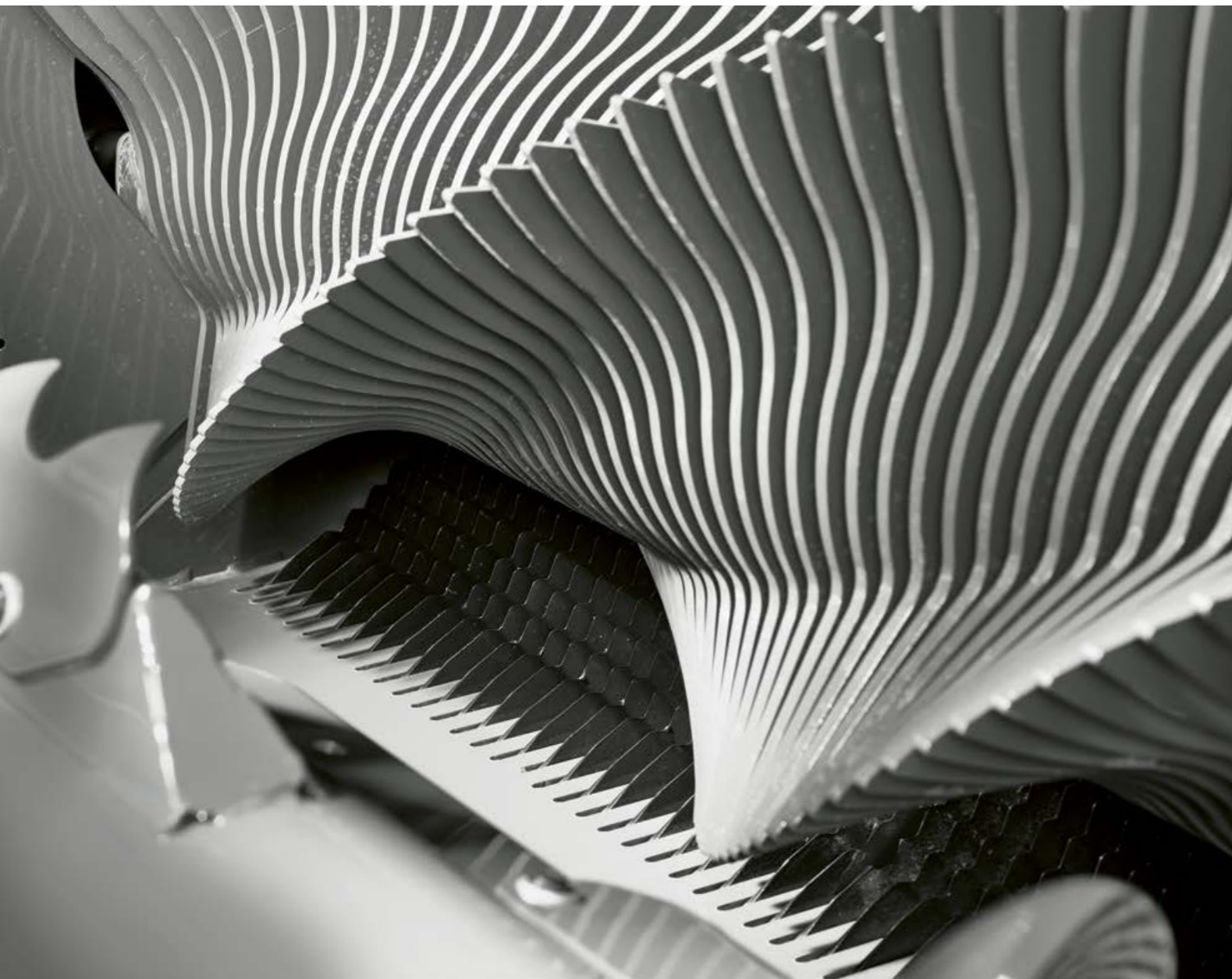

FINE CUT – hardly a stalk longer than 22 mm.

Happy animals produce better yields. For example, there is a marked increase in the rumen action of animals fed a mixture of short straw and silage. And it's hard to find a better bedding material than short straw. It's almost entirely dust-free, since the cutting action prevents dust from getting in. Furthermore, short straw is increasingly being added to the feed mixer. FINE CUT straw breaks down easily, with no pre-mixing required, and it mixes directly with the added silage.

A fine cut – for optimum bedding quality.

- Advantages for livestock farming and operating costs
- Easy to loosen, less force needed to spread, not frayed
  - Excellent for higher animal health in poultry farming
  - Provides excellent structure in livestock feed
  - Shorter mixing times in the feed mixer
  - Diesel saving

The user-friendly knife group activation.

FINE CUT by CLAAS has been available since 2000 already. The FINE CUT generation of the QUADRANT EVOLUTION opens up a new dimension of straw and cutting quality for you. Apart from the tried and tested knife group distribution of 51, 26, 12 and 13 knives, you now also have another option of 51, 26, 25 and 13 knives.

There are four good reasons for this: more effective cutting, maximum time savings, less maintenance and less wear. You can, for example, be cutting with 26 knives, while the 25-knife group remains protected in the cutting trough. As soon as the 26-knife group needs sharpening, you can swap it immediately for the 25-knife group. Work continues without interruption, and the knives you have just removed can be sharpened in the meantime.

At a glance.

- High forage quality thanks to FINE CUT
- Good livestock practice: a fine cut for optimum bedding quality
- New knife group activation means less maintenance and saves time.
- Better crop intake and reduced residue
- Stimulation of rumen action
- Increase of overall crop intake
- Cuts the time for replacement of food residues and cleaning of feeding stations

QUADRANT	5300	5200	4200
FINE CUT	□	□	□
Knife group activation 1	51, 26, 13, 12, 0	51, 26, 13, 12, 0	51, 26, 13, 12, 0
Knife group activation 2	51, 26, 25, 13, 0	51, 26, 25, 13, 0	

□ Available – Unavailable



# The CLAAS knife drawer – what you use frequently should always be on hand.



This is how the CLAAS knife drawer works.



## Ten benefits of the CLAAS drawer system:

- 1 Total of twelve well-protected, reliably clean, easily gliding bearings for pulling out the knife drawer
- 2 Knife group activation for RC/FC operable via a simple lever for a theoretical length of cut of 90, 45 or 22 mm
- 3 Optimal knife shape for perfect cutting quality
- 4 Exclusive: automatic knife cleaning
- 5 Set of dummy knives available for RC and FC
- 6 Automatic function for convenient lowering and closing of knife drawer
- 7 Convenient operation of CLAAS drawer system directly from the baler
- 8 100% accessibility, thanks to two-sided pullout
- 9 Exclusive: the cutting frame automatically lowers hydraulically in the event of blockage
- 10 Individual blade protection with two springs per knife

## Convenient: the knife drawer.

The CLAAS knife drawer for ROTO CUT and FINE CUT simplifies maintenance routines.

### Quick, convenient and safe:

- Operation via the tractor control panel or directly via buttons on the side of the baler
- Automatic function: knives swing in and out to eliminate dirt from the knife slots of the cutting trough
- Automatic and therefore consistently accurate positioning of drawer for easy extraction at each side

## Well-protected knives cut better.

The knives in the knife drawer are optimally protected against dirt accumulation. A total of 12 bearings allow the drawer to be pulled out smoothly and easily. To prevent twisting upon extraction, the knife drawer slides out by only two-thirds at either side. After replacing the knives on one side, the drawer is simply slid to the opposite side to replace the remainder.

Unique: the knife drawer is combined with the cutting trough, which, as before, can be lowered automatically in the event of a rotor blockage.

## At a glance.

- The QUADRANT 4200 now also has an easily accessible knife drawer
- Maximum reliability and service life, thanks to well protected knives



“The time required to change the knives has been cut from one hour to just 15 minutes, and the maintenance time as a whole is significantly less.”

Albert Steyns, contractor, Lontzen, Belgium



# Short cuts to keeping your animals healthy and happy.



## The finest forage quality with SPECIAL CUT.

Cut short straw is enormously absorbent, making it the ideal bedding for dairy cattle cubicles, pigsties and horse boxes. The high absorptive capacity keeps the animals clean and reduces straw consumption. Clean udders are also an important part of dairy hygiene – and they make milking faster. Cut straw can be mixed well with maize-rich rations. The animals are not selective, and they eat up all of the feed ration.

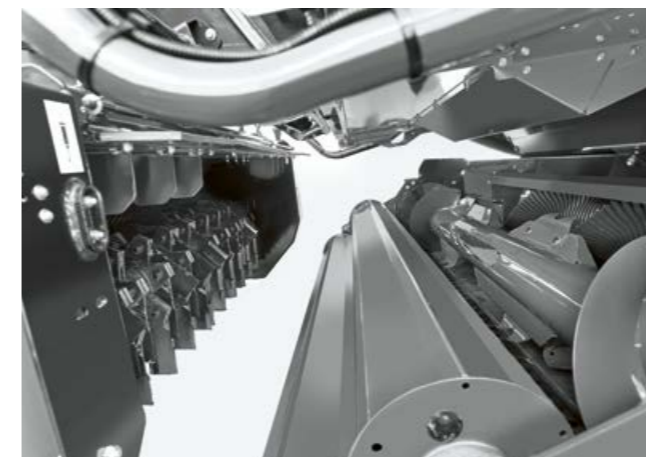

## The SPECIAL CUT chopper.

The SPECIAL CUT chopper blows the straw into the rotor along a direct route beneath the auger of the POWER FEEDING SYSTEM (PFS) – no swirling up or material congestion. This helps prevent dust accumulation and boosts the throughput volume for maximum operational reliability.

The double spiral rotor with 88 knives ensures high cutting quality and even crop flow at a working width of 2 metres. The two rows of knives can be set up as shear bars at several levels with 45 knives each.

### At a glance.

- SPECIAL CUT: Short-cut straw is the ideal bedding for barn-raised animals
- Increased throughput, improved reliability: the chopper
- Efficient baling with or without chopper – with a ground clearance of more than 500 mm
- High bale density and precise bale shape ensure the bales remain stable during transport.



## High bale density means stable bales.

Cut straw also allows for optimal handling in large square bales. For transporting, the high bale density and precise bale shape ensure that the bales remain stable even when they are relocated multiple times. Moreover, significantly higher weights per bale ensure fewer bales per hectare, reducing handling requirements.



# Technologies for the perfect bale. QUADRANT EVOLUTION 5300 / 5200 / 4200.

For over 30 years, CLAAS square balers have offered unique details in addition to an ingenious overall design: FINE CUT technology produces dust-free short straw with firm bales that remain stable during transport. The drive is completely chain-free in all QUADRANT EVOLUTION balers – yet another plus for greater reliability during the harvest. The HD-II knotter ensures maximum knotting reliability – even in the toughest conditions.





Think inner qualities can't be seen?  
Take a closer look.

Prechamber, packer, bale chamber.

Often, it is precisely the things you don't see that make all the difference. This is also true for our balers. The following pages bring these differences to light: innovative, technically sophisticated solutions that ensure that your work runs smoothly.

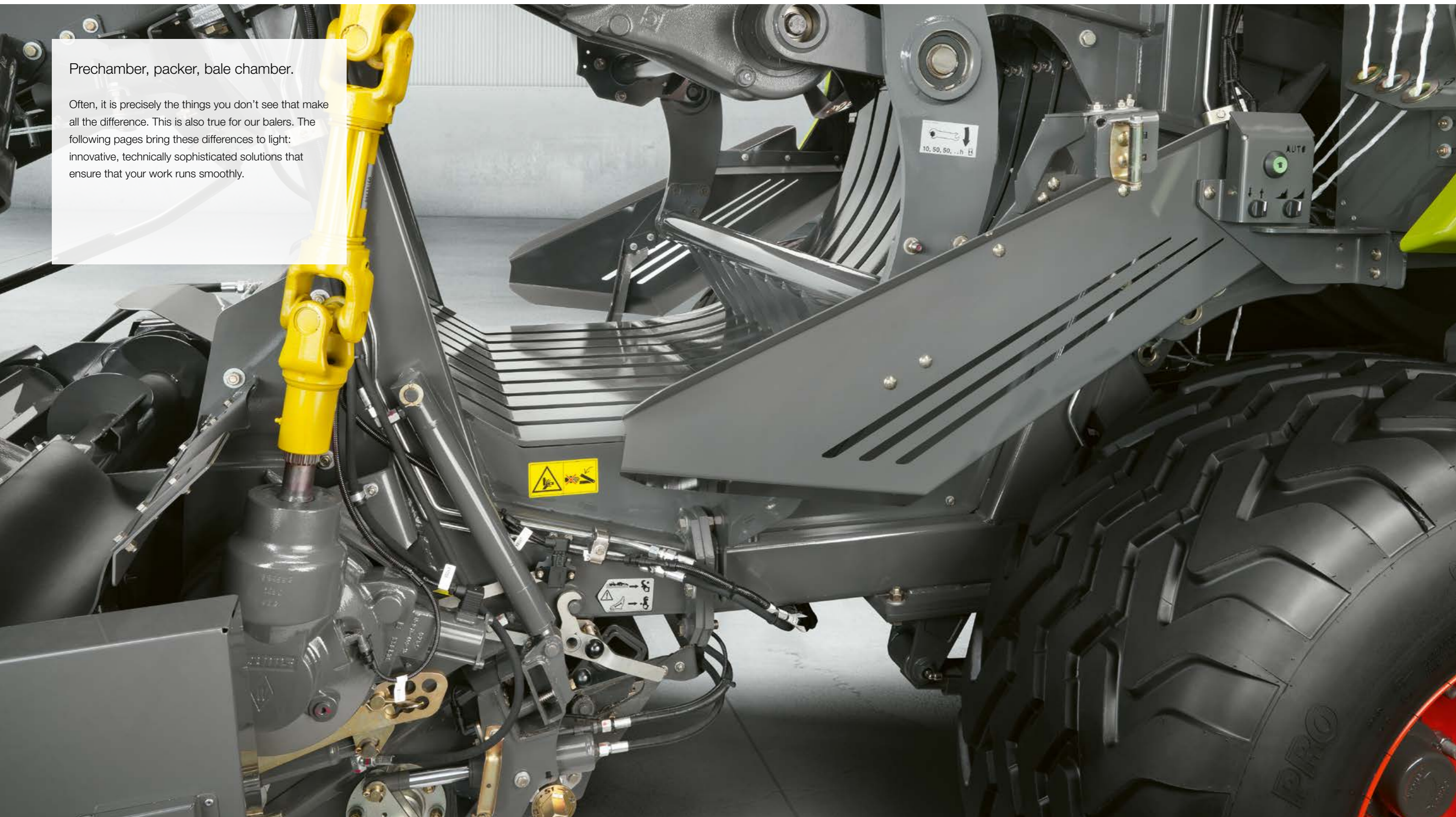



Is the pressure getting too much?  
We can help keep it under control.



Unique to CLAAS: the hydraulically adjustable prechamber.

Depending on the consistency of the crop and swath size, the prechamber pressure can be selected from three available options via the ISOBUS control terminal, allowing the machine to be utilised at maximum output at all times. Regardless of the swath and crop conditions you come across, you can bring everything under control with the adjustable, hydraulically actuated prechamber.



Unique crop flow concept.

An even crop transport from the rotor to the packer and the adjustable prechamber ensures homogeneous filling of the chamber with all crop types, whether straw, hay or silage. The result is firm, well-shaped and conveniently storable bales with maximum throughput and a cutting performance that speaks volumes.



Find out more about the hydraulic prechamber.



Scan me.

At a glance.

- Exclusive to CLAAS: the prechamber can be adjusted from the comfort of the driver's seat.
- Even filling of the chamber for all crop types: the CLAAS crop flow concept
- Perfect bale shape and consistent density: the hydraulic packer control is impressive whatever the conditions.
- Safe and reliable: the packer and rotor are protected via a clutch.

Hydraulic packer control.

For large swaths, the QUADRANT produces bales without the prechamber. In all other cases, you can activate the hydraulic and wear-free packer control effortlessly from the cab.

Three different settings ensure optimal compaction in all conditions. Whether the machine is configured for medium or small swaths, each bale is always optimally filled and the harvested crop is forced into the chamber in a single stroke. The result is a perfect bale shape with even compaction, even when baling irregular or small swaths.

Only from CLAAS: equipped with two paddle shafts and sensors, the QUADRANT gathers the harvested crop until the prechamber is optimally filled.



Adjustable prechamber control.

The prechamber can be adjusted from the comfort of the cab, so that you can be sure of the best results, no matter what the crop type or volume.

QUADRANT	5300	5200	4200
----------	------	------	------

Adjustable hydraulic prechamber	□	□	–
Fixed-cycle prechamber	–	–	□

□ Available – Unavailable

Automatic prechamber.

The CLAAS packer on the QUADRANT 4200 does an excellent job. The forage is transported and processed at high throughput with effective protection of the leaf material in 3:1 mode.

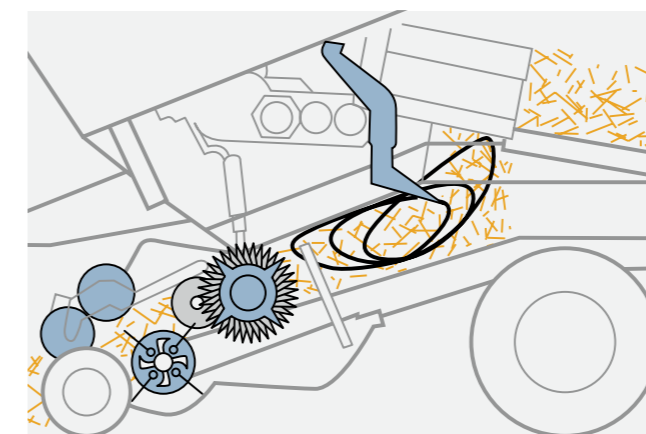



Runs like clockwork thanks to momentum and safety.



**Dependable drive concept.**

QUADRANT balers have impressed operators for years in daily operations with their absolutely reliable drive design. Clearly arranged and easily accessible components ensure high efficiency and a long service life. The design ensures outstanding efficiency by transmitting all power along short, straight lines using a very large flywheel. Lowest possible energy consumption per tonne of crop is reflected in lower fuel bills.

**Intelligent safety technology.**

Superior safety technology ensures fault-free operation. The cleverly designed drive of the packer, needles and knotters via the shafts and transmission offers dependable peak performance. An overload clutch in the main transmission effectively protects the baler against damage caused by foreign objects.

**Overload clutch protects machine from jamming.**

The packer and rotor are fitted with separate automatic overload protection devices. Whenever the packer clutch engages, the rotor clutch is disconnected automatically. All overload clutches automatically re-engage when the PTO shaft speed is brought back down. You'll never need to leave the driver's seat in the event of a blockage. If required, the cutting frame can be lowered via the tractor hydraulics.

The result: the QUADRANT will never be driven to a standstill. You can quickly clear any blockages from the comfort of the tractor seat. The packer is effectively protected with an additional tailor-made power interrupt clutch, so that the machine will never get jammed. In the new QUADRANT 5300 and 5200, the high baler throughput is protected with a 30% stronger clutch. High performance is assured by a torque increase of 26%.

Outstanding features that have been setting the standard for years:

- High speeds and low torque
- Maintenance-free drives and clutches operating in an oil bath
- Maintenance-free packer drive with hydraulically adjustable prechamber
- Divided power flow: baling pistons, packer, pick-up and rotors are powered separately
- Minimum number of moving parts

**Greater mass for more momentum.**

- Large flywheel with up to 28% more mass and 46% more inertia compared to the previous version
- The automatic overload clutch replaces the shear bolt. This increases driver comfort
- Load peaks are balanced, which protects the machine
- Significant fuel savings

At a glance.

- Extremely reliable, thanks to enhanced drive concept
- Disruption-free work: smart safety technology enables maximum performance without interruption.
- Jamming of the machine is almost impossible thanks to special protection
- Diesel savings thanks to more mass in the flywheel
- New flywheel version: greater efficiency due to increased mass and inertia

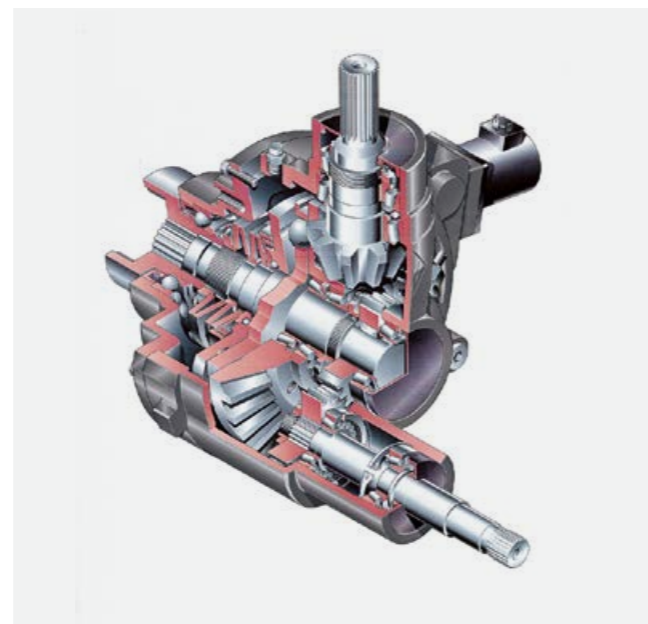

Maintenance-free safety: high-quality clutches with oil bath lubrication protect the QUADRANT against overload.

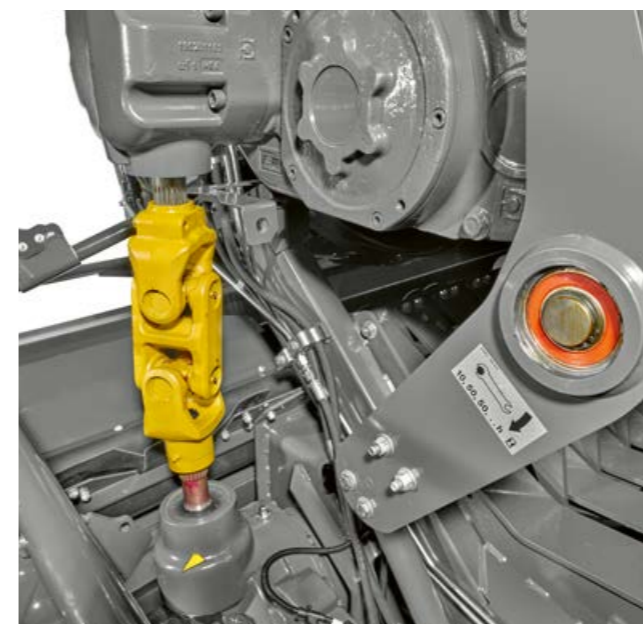

Dependable drive concept.



A must-have on the field:  
consistent baling pressure.



Scan me.

Find out more about  
automatic baling  
pressure control.



At a glance.

- Only from CLAAS: automatic baling pressure control for consistently uniform bale density and high operating comfort
- Easy to operate: even inexperienced drivers achieve maximum performance thanks to preset control variables for automatic baling.

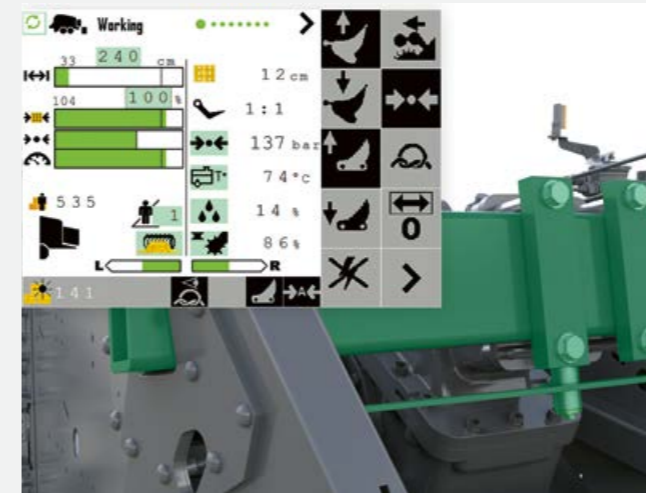

The automatic baling pressure control detects and displays the load on the baler frames.

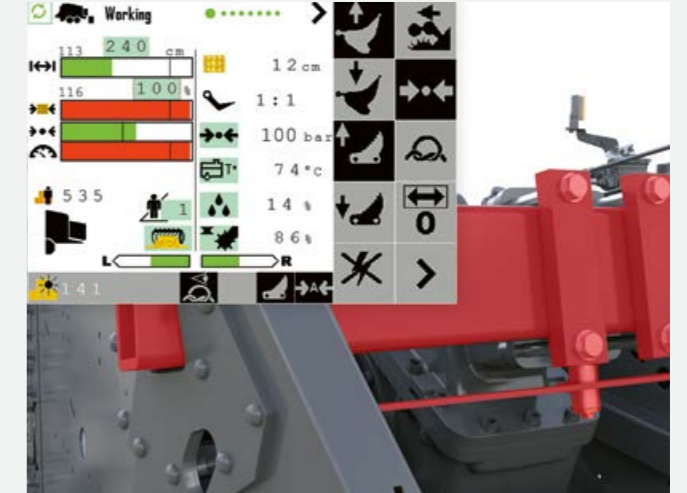

The sensor on the main frame measures the applied baling pressure. The measured values are displayed to the driver on the CEMIS 700. The system regulates the load limits based on these values.

Unique to CLAAS: the automatic baling pressure control.

There are many baling pressure controls on the market, but the APC automatic baling pressure control is only available from CLAAS. It regulates the baling pressure depending on the load on the main frame.

Drivers can conveniently keep an eye on load limits at all times, without any need for active intervention. The machine sets the optimum baling pressure fully autonomously depending on the crop.

The benefits are self-evident:

- Consistently high bale density, even when operating at the limit capacity of the machine and the twine
- The bales produced throughout the day are compacted with consistent density
- Maximum driving comfort thanks to straightforward operation and easy handling, especially for inexperienced baler drivers

Simple operation, maximum results.

The parameter to be set for automatic baling is the load on the baler frame. Since the baling pressure is regulated automatically, even inexperienced baler drivers can operate the machine effortlessly and continuously at its performance limit. The maximum baling density for the individual crop is saved in the menu beforehand. The system then sets the load limit based on the stored values.



# How do we respond to pressure? Hard and fast.



Improved bale shape – rock-hard bales all the way.

Bale more mass with the new QUADRANT. The shape and length of the bale chamber in the QUADRANT 5300 and 5200 have been revised to achieve an even better bale shape and greater bale density. This allows you to bale more weight per cubic metre and achieve greater tonnage outputs per hour. The extended end section of the bale chamber provides space for bales to expand lengthwise, gradually increasing the tension on the twine. The risk of the twine breaking is therefore reduced to a minimum.

As a professional, you'll appreciate the redesigned bale chamber:

- Better bale shape, thanks to several retainers in the bale chamber and the new channel side shape
- New side retainers for higher density
- Longer 3.85-m chamber in the QUADRANT 5300 and 5200
- Reliable tying with less bale expansion through the open side panels of the bale chamber

The new chamber concept for high density.

The new, strengthened octagon on the QUADRANT means even greater bale density. The new baling piston design makes for even sharper bale edges. With the side retainers, the new upper baling flap and the new side panels, all bales reach their maximum density level. Their uniform length and even bale expansion on the sides result in more reliable tying on ejection. In short: the QUADRANT produces bales of consistently high density with optimal cubic metre compaction.

Durable heavy-duty piston track rollers.

Count on the (optional) new heavy-duty piston track rollers if you bale more than 10,000 bales per year. The pistons run on double-row, automatically lubricated HD ball bearings, which have a significantly longer service life and do not need to be replaced.

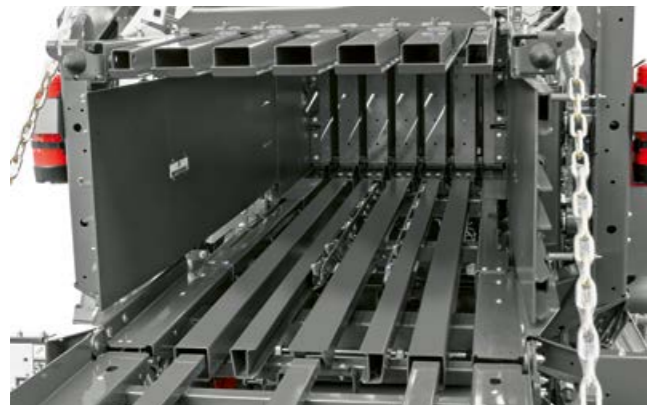

### At a glance.

- Better bale shape and higher tonnages per hour, thanks to redesigned bale chamber
- New chamber concept for optimal bale density and reliable tying



HD piston track rollers with reinforced bearings and optimised sealing.



The rotating knives can be mounted in two positions for use in straw / maize straw or in hay / silage.

QUADRANT		5300	5200	4200
Bale chamber length	m	3.85	3.85	3.45
Bale chamber width	m	1.2	1.2	1.2
Bale chamber height	m	0.9	0.7	0.7

□ Available – Unavailable

Everything about the new bale chamber.



Scan me.



Double is better:  
tandem axles for greater comfort and safety.

**Axles and tyres.**

For minimal ground pressure, maximum protection of the grass cover and smooth running, the QUADRANT comes with a choice of axles with a range of large-volume tyres. These offer a maximum contact area and thus minimise damaging ground pressure even on very light or wet soils.



QUADRANT	5300	5200	4200
Single axle 600/50 R 22.5	–	<input type="checkbox"/>	<input type="checkbox"/>
Single axle 710/40 R 22.5	–	<input type="checkbox"/>	<input type="checkbox"/>
Tandem axle 520/50 R 17	–	–	<input type="checkbox"/>
Tandem axle 500/55 R 20	<input type="checkbox"/>	<input type="checkbox"/>	<input type="checkbox"/>
Tandem axle 620/50 R 22.5	<input type="checkbox"/>	<input type="checkbox"/>	<input type="checkbox"/>
Steered tandem axle 500/55 R 20	<input type="checkbox"/>	<input type="checkbox"/>	<input type="checkbox"/>
Steered tandem axle 620/50 R 22.5	<input type="checkbox"/>	<input type="checkbox"/>	<input type="checkbox"/>

Available     Unavailable



## The knotter hook.

Almost legendary: the knotter hook was the first CLAAS product to be patented, back in 1921, and more than a million have been produced since. We have developed our knotter continuously over the years, as baling pressures have increased steadily and our customers demand more secure knots. The CLAAS knotter ensures functionality and reliability in all conditions and with any type of twine.

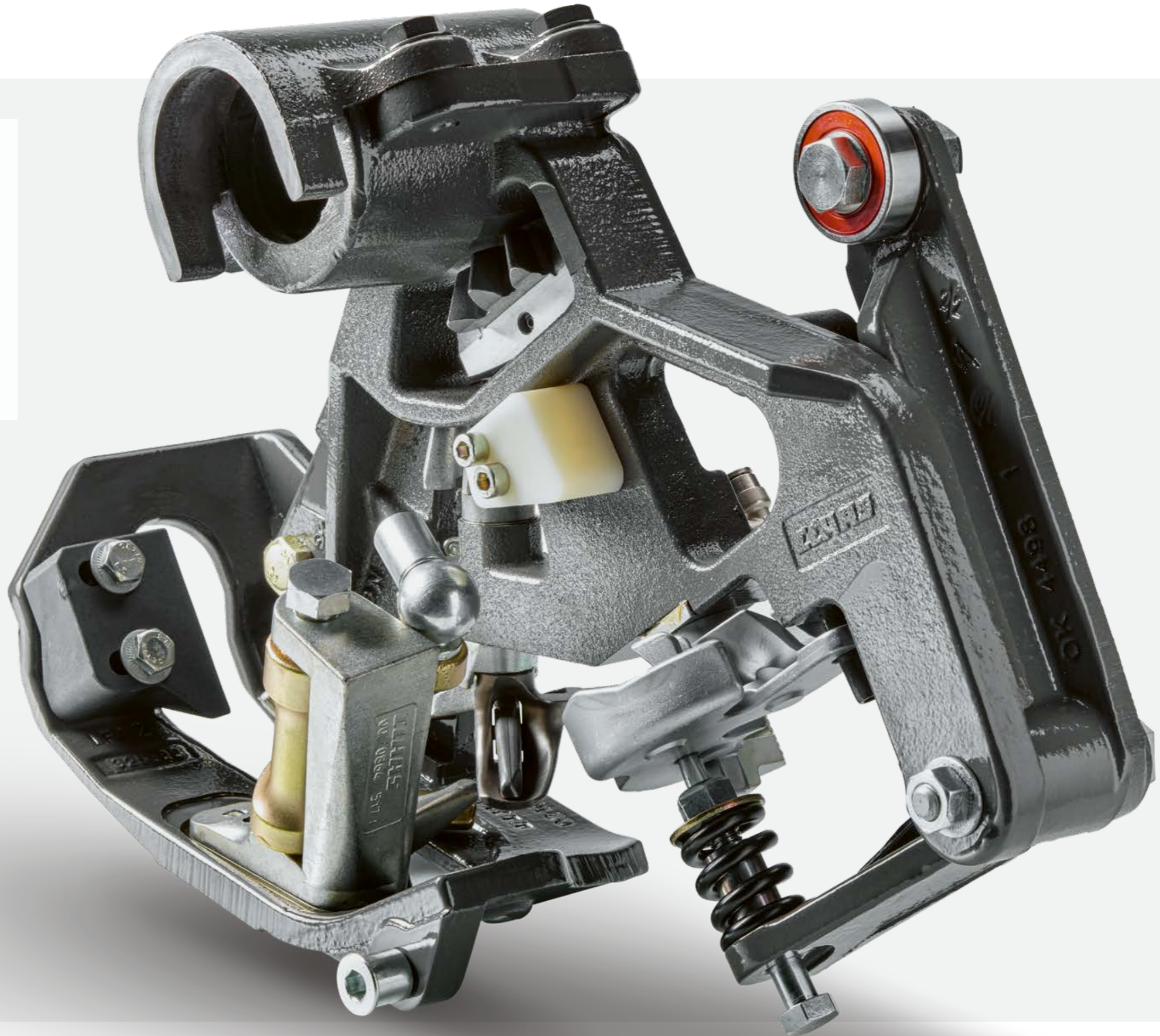



We're totally committed to our work – and, of course, to you.



At a glance.

- Quick, precise, reliable: the CLAAS knotter
- Safe and clean: knotting with no twine residue with the new knotter blower
- Economical, strong and wear-resistant: the CLAAS baling twine



QUADRANT	5300	5200	4200
Number of knotters	6	6	6
TURBO FAN knotter cleaning system	With air diffuser	With air diffuser	With air diffuser
Twine box capacity	24 x 11.5 kg	24 x 11.5 kg	24 x 11.5 kg

□ Available – Unavailable

The CLAAS knotter.

CLAAS balers just would not be the same without the legendary CLAAS knotter. Today, CLAAS remains the only agricultural machinery manufacturer worldwide to develop and manufacture its own knotters. The operating principle is direct drive via universal cardan shaft. The result is high speed operation, razor-sharp precision and total reliability.

Powerful knotter fan producing 140 km/h.

The knotter design with active twine finger assembly, aggressive clamp plate and electromechanical tying actuation increases the tying reliability under all conditions. The direct drive ensures permanent synchronisation between the pistons and needles. The needles cannot collide with the pistons. In the QUADRANT 5300, which produces 90-cm-high bales, the needles are eccentrically controlled to leave more time for producing the knots.

A further advantage: the knotters do not produce dangerous twine off cuts that can cause animal fatalities during feeding or leave residues when the material is used for power generation. The hydraulically driven TURBO FAN system with its active airflow protects the knotter from dust and dirt, with a powerful and constant 140-km/h airflow and air diffusers.

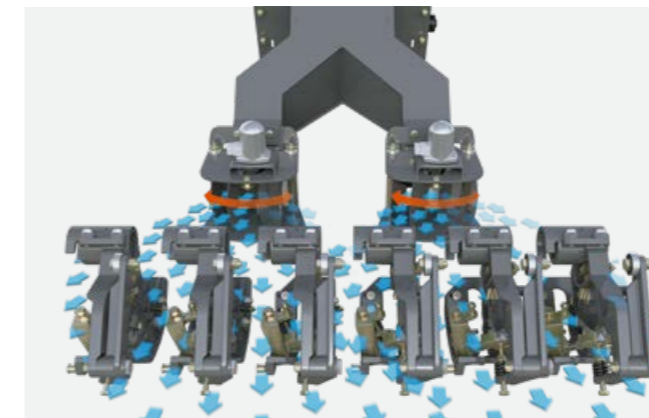

Practical twine box.

The dust-tight twine boxes can hold 24 reels of twine. Thanks to the CLAAS HD-II knotter system, each knotter only needs one reel of twine at a time. A new feature is the folding twine guide, which makes it easy for shorter people to insert the twine. The tool-free twine brake adjustment and the hand wash container, which comes as standard, leave nothing to be desired when it comes to twine storage. Bright work lamps provide good illumination around the two twine boxes, the twine guide and knotters.

More economical tying with CLAAS twine.

CLAAS baling twine is specifically designed for the CLAAS knotter. It is strongly resistant to tearing and at the same time supple enough to minimise knotter wear. Every time twine is replenished, four reels of twine per knotter can be tied together without needing to change in between. This saves time and ensures a good balance between knot strength and usable length of twine. The large twine box holds 24 reels of 11.5 kg twine each – plenty even for a long working day.



Optional: space for 12 additional twine reels. Depending on reel size, that is enough for about 350-400 bales.



If you take the lead, you're bound to succeed.

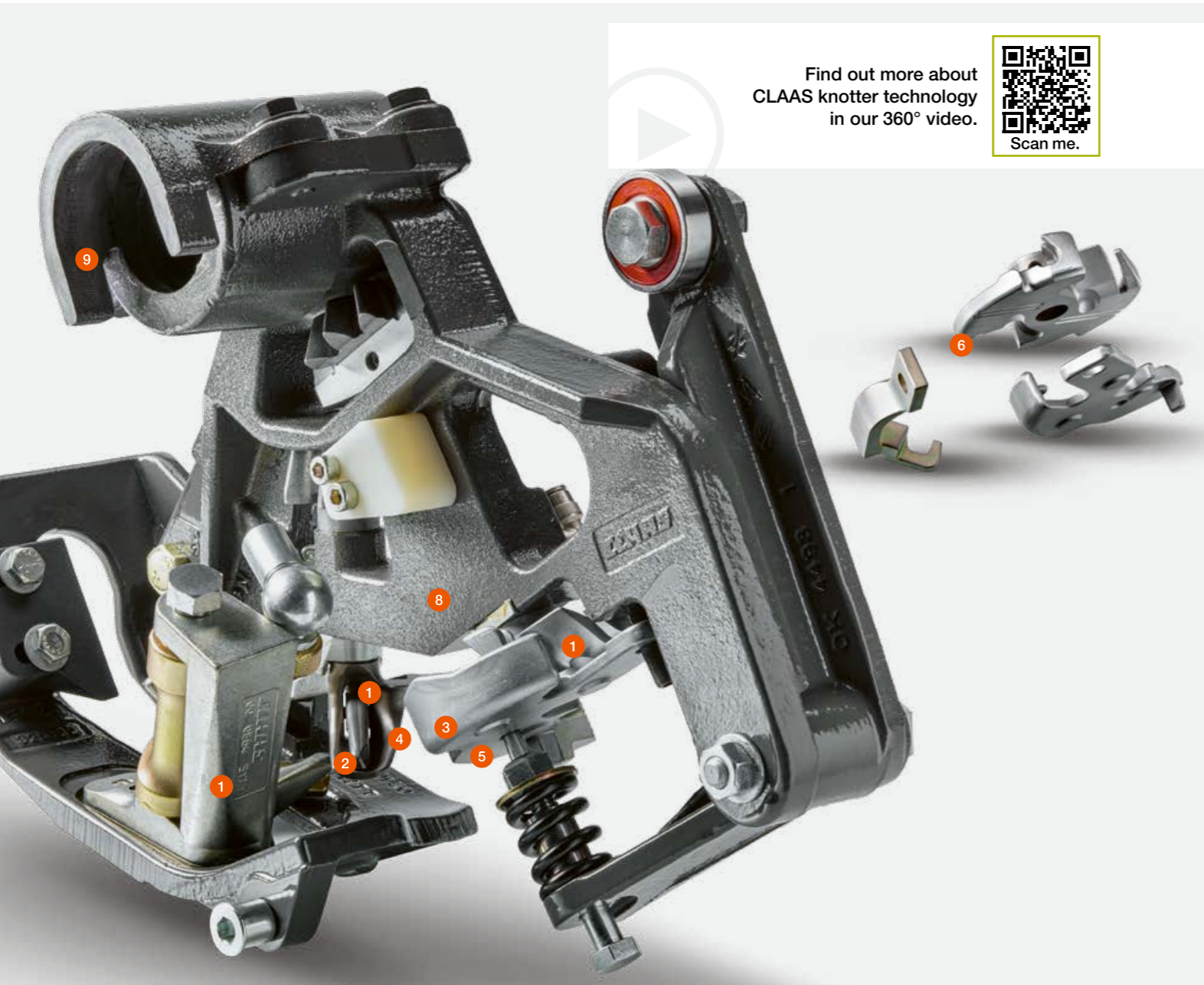

### Long service life for knotter technology.

The knotter hook, twine retainer wheel and clamp plate are subjected to a heating process during their manufacture to ensure maximum wear resistance and a long service life.

### The new functions at a glance.

- 1 Larger opening in the knotter hook creates more insertion space and more reliable threading of the twine
- 2 Tapered and therefore more wear-resistant knotter tongue redesigned for easier knot execution
- 3 New twine retaining plate and twine retainer wheel to secure the twine firmly during the tying process for even higher bale density
- 4 New cam section for improved twine guidance
- 5 New twine retaining plate to handle thicker tying material
- 6 New twine guide path design for easier twine insertion
- 7 Closed twine applicator for reliable guidance
- 8 Error-free insertion of the twine into the knotter, thanks to the wider angle between the knotter hook and twine retainer wheel (7.6°) – this means longer twine ends, and hence a better knot
- 9 Swivelling knotter with quick-release mounting for ease of maintenance



### The improved knotter hook.

The knotter hook has been significantly further enhanced in the new QUADRANT 5300, 5200 and 4200 with stronger material and reworked geometry. This ensures operational reliability for all types of twine in all operating conditions.

### Knotter monitoring.

The sensors (6) on the knotter bank ensure that the driver sees in real time on the CEMIS 700 terminal whether the twine is about to run out. These sensors also feed into the left/right indicator. The result: drivers can operate the baler to its full capacity limit without twine breakage. And even if the twine breaks, the knotter monitoring system immediately alerts drivers.

### At a glance.

- Hard-wearing: knotter technology from CLAAS
- Enhanced functions: e.g. eccentric needle control on the QUADRANT 5300
- Ready for the task whatever the conditions: the optimised knotter hook
- Absolute tying reliability in daily use thanks to knotter monitoring



Need to watch your weight?  
No problem!



Integrated bale weighing system.

A long bale chamber, high ram frequency and automatic baling pressure control ensure high compression on the QUADRANT series under all conditions. You can now also easily set the weight for your finished bales: four sensors measure the weight with a high level of precision right on the bale ramp. This gives contractors and farm owners alike an overview of how many tonnes of bales have been produced for a particular area. It also means that, where required, they can invoice fairly based on the number of tonnes, in a way that is transparent for both parties.

The possibilities of data transfer.

With the new bale weighing system, the exact bale weight is displayed on the terminal during working, and is saved to the customer order. Once saved, the weights of individual bales can be called up anywhere via TELEMATICS and undergo further processing. Task management can also be used for invoicing purposes.

At a glance.

- Bale weighing system available for all QUADRANT models
- Improve operating times, support the operator, optimise costs – all with remote access
- All important data, e.g. weight, can be accessed via TELEMATICS on IMPLEMENT (TONI) or task management



QUADRANT	5300	5200	4200
Bale weighing system	<input type="checkbox"/>	<input type="checkbox"/>	<input type="checkbox"/>

Available – Unavailable



# Machine operation with the CEMIS 700 terminal.

## Our goal:

Offering great user-friendliness and high operating comfort with robust implements and innovative technology.

## Key features:

- Access all the important functions directly from the driver's seat
- All QUADRANT are ISOBUS-compatible
- CEMIS 700 operating terminal for greater comfort



Touchscreen operation.

Simply tap the 7" touchscreen on the CEMIS 700 to select the function you require directly. The simple navigation menu allows you to quickly and conveniently activate the knives or open and close the lowerable floor, for example.



Ergonomic control terminal.

- Simple control inputs make for easier use on the field
- Can also be operated via a rotary pushbutton and keys, in addition to the touch function
- The proven CLAAS control logic and symbols make this terminal easy to use



Job counter for 20 customers.

- Logs important figures, enabling you to provide greater transparency for customers:
- Total number of bales
  - Number of bales per day
  - Total number of chopped bales
  - Working time at customer's site



Two camera inputs.

- Connection for two cameras
- Greater convenience and better machine control
- Fewer screens in the tractor cab



# A simple step for saving time.

## CEBIS Touch.

CLAAS tractors with CEBIS Touch control unit are also ISOBUS-compatible. The integrated ISOBUS implement control allows all functions to be displayed and operated. Up to 10 ISOBUS functions can be activated and deactivated via function buttons on the CMOTION in the tractor.



## Comfort on the field.

The (optional) hydraulically folding castor guide wheels are automatically folded out for work. When the pick-up is in the air, the wheels are folded in.

	CEMIS 700	CEBIS Touch
<b>The terminal</b>		
ISO UT	–	<input type="checkbox"/>
TONI-enabled	–	<input type="checkbox"/>
Y cables	<input type="checkbox"/>	–
Touch screen	<input type="checkbox"/>	<input type="checkbox"/>
Colour screen	<input type="checkbox"/>	<input type="checkbox"/>
Camera	<input type="checkbox"/>	–
<b>Settings</b>		
8 presets (straw, hay...)	<input type="checkbox"/>	<input type="checkbox"/>
Bale length	<input type="checkbox"/>	<input type="checkbox"/>
Baling pressure	<input type="checkbox"/>	<input type="checkbox"/>
Lubrication interval	<input type="checkbox"/>	<input type="checkbox"/>
Knife position	<input type="checkbox"/>	<input type="checkbox"/>
Automatic baling pressure control	<input type="checkbox"/>	<input type="checkbox"/>
Hydraulic prechamber	<input type="checkbox"/>	<input type="checkbox"/>
PFS speed	<input type="checkbox"/>	<input type="checkbox"/>
Twine quality	<input type="checkbox"/>	<input type="checkbox"/>
Knife cleaning cycle	<input type="checkbox"/>	<input type="checkbox"/>
<b>Information in the task menu</b>		
Bale length	<input type="checkbox"/>	<input type="checkbox"/>
Baling pressure	<input type="checkbox"/>	<input type="checkbox"/>
Package size	<input type="checkbox"/>	<input type="checkbox"/>
Left/right indicator	<input type="checkbox"/>	<input type="checkbox"/>
Knife position	<input type="checkbox"/>	<input type="checkbox"/>
Number of bales	<input type="checkbox"/>	<input type="checkbox"/>
Piston strokes/min	<input type="checkbox"/>	<input type="checkbox"/>
Automatic baling pressure control	<input type="checkbox"/>	<input type="checkbox"/>
Hydraulic prechamber	<input type="checkbox"/>	<input type="checkbox"/>
Moisture sensor	<input type="checkbox"/>	<input type="checkbox"/>
Weighing data	<input type="checkbox"/>	<input type="checkbox"/>
Bale deposit sensor	<input type="checkbox"/>	<input type="checkbox"/>
Bale weighing system	<input type="checkbox"/>	<input type="checkbox"/>
<b>Customer menu</b>		
20 customer orders	<input type="checkbox"/>	<input type="checkbox"/>

Available – Unavailable



## Comfortable bale ramp operation.

You can (optionally) open and close the bale ramp conveniently from the cab to save you a lot of time in the field. This function is controlled via the ISOBUS control unit. Thanks to the factory-fitted rear camera, you always have a full view of the area behind the baler. Residual bales can be ejected and the bale ramp be folded in subsequently.



## Save time.

You can eject the bale and fold in the baler ramp at just a tap of the finger. Drivers save about 5 to 10 minutes with each field change, allowing them to boost their output.



Whatever it takes –  
CLAAS Service & Parts.



CLAAS Service & Parts is always  
there for you, 24/7.  
[service.claas.com](http://service.claas.com)



Scan me.

The CLAAS Service & Parts product range may vary from country to country.



**Specially matched to your machine.**

Precision-manufactured parts, high-quality consumables and useful accessories. Choose our comprehensive product range to be certain of receiving exactly the right solution to ensure 100% operational reliability for your machine.



**For your business: CLAAS FARM PARTS.**

CLAAS FARM PARTS offers one of the most comprehensive ranges of multi-brand parts and accessories for all agricultural applications on your farm.



**Global supply.**

The CLAAS Parts Logistics Center in Hamm, Germany, stocks almost 200,000 different parts and has a warehouse area of over 183,000 m<sup>2</sup>. This central spare parts warehouse delivers all ORIGINAL parts quickly and reliably all over the world.



**Your local CLAAS distributor.**

Wherever you are, you can count on us to always provide you with the service and the contact persons you need. Your CLAAS partners are on hand in your local area, ready to support you and your machine around the clock. With know-how, experience, commitment and the best technical equipment. Whatever it takes.





### Reduced maintenance outlay, central lubrication.

There's almost no need to even mention maintenance.

Because it simply isn't an issue for QUADRANT owners. Everything in the QUADRANT 5300, 5200 and 4200 is designed to be easy to maintain or to be maintenance-free in the first place.

- In the QUADRANT 5300 and 5200, all key lubrication points feature automatic, continuous central grease lubrication as standard; in the QUADRANT 4200 you have a choice between automatic or electric central lubrication.
- Drives and overload clutches run in an oil bath.
- The hydraulically controlled packer is entirely maintenance-free.
- The drive has only a minimal number of moving parts.

Exclusive to CLAAS: the steered tandem axle is also supplied via the central lubrication.

With so little time wasted on maintenance of the QUADRANT 5300 and 5200, you can spend more time out on the field, and the convenient maintenance lighting turns night into day. There are normally four LED lights for driving, with another seven that can be switched on for maintenance works.

Tool cabinet with clean water tank. As a baling professional, you need a little extra storage space on your baler on long harvesting days, whether for special tools, a leaf blower or simply a clean place for your work gloves. The new, sealed optional tool box offers sufficient space for this. The integrated clean water tank even has space for a soap dispenser.

### At a glance.

- LED maintenance lighting with 11 LEDs for an optimal view.
- Automatic lubrication, including the steered tandem axle, means less maintenance



QUADRANT		5300 RF	5300 RC	5300 FC	5200 RF
<b>Attachment</b>					
PTO shaft speed	rpm	1000	1000	1000	1000
Hydraulic jack		●	●	●	●
Ball hitch		○	○	○	○
Hydraulic connection		2 single-acting and 1 open return line	2 single-acting and 1 open return line	2 single-acting and 1 open return line	2 single-acting and 1 open return line
<b>Pick-up</b>					
Width	m	2.35	2.35	2.35	2.35
DIN rake width	m	2.15	2.15	2.15	2.15
Number of tine bars		5	5	5	5
2 oscillating pick-up castor guide wheels		●	●	●	●
POWER FEEDING SYSTEM (PFS)		●	●	●	●
Hydraulically driven PFS		○	○	○	○
<b>Feed for driven feeder unit</b>					
Rotor		ROTO FEED	ROTO CUT	FINE CUT	ROTO FEED
Number of knives		–	25	51	–
Blanked-off knives		–	●	●	–
Knife group activation		–	25, 13, 12, 6, 0	51, 26, 13, 12, 0 / 51, 26, 25, 13, 0	–
Knife drawer		–	●	●	–
Adjustable hydraulic prechamber		●	●	●	●
Fixed-cycle prechamber		–	–	–	–
<b>Bale chamber</b>					
Ram strokes	rpm	46	46	46	56
Max. baling pressure	bar	200	200	200	200
Automatic baling pressure control		●	●	●	●
Bale ejector		●	●	●	●
Bale deposit sensor		●	●	●	○
Moisture sensor		○	○	○	○
<b>Bale chamber dimensions</b>					
Length	m	3.85	3.85	3.85	3.85
Width	m	1.20	1.20	1.20	1.20
Height	m	0.90	0.90	0.90	0.70
Bale length	m	0.50-3.00	0.50-3.00	0.50-3.00	0.50-3.00
<b>Operation</b>					
CEMIS 700		●	●	●	●
ISOBUS cables		○	○	○	○
Automatic central lubrication		●	●	●	●
LED package		○	○	○	○
Bale weighing system		○	○	○	○
<b>Baling</b>					
Number of knotters		6	6	6	6
Knotter monitoring		○	○	○	○
Number of twine reels in air diffuser		24 x 11.5 kg	24 x 11.5 kg	24 x 11.5 kg	24 x 11.5 kg
TURBO FAN knotter cleaning with active air distribution		●	●	●	●
HIGH SPEED BINDING		●	●	●	–
2 additional twine boxes (2x6)		○	○	○	○
<b>Bale drop onto field</b>					
Depositing chute, mechanically folding		●	–	–	●
Depositing chute, hydraulically folding		○	–	–	○
Hydraulically folding roller chute		○	●	●	○
<b>Dimensions and weights</b>					
Width	m	2.90-2.99	2.90-2.99	2.90-2.99	2.89-2.99
Height	m	3.36-3.43	3.36-3.43	3.36-3.43	3.08-3.15
Length in transport position	m	8.86	8.86	8.86	8.1
Length in working position	m	9.86	9.86	9.86	9.32
Weight (with tandem axle)	kg	11195-14750	11195-14750	11195-14750	8700-12500

● Standard ○ Optional – Unavailable

5200 RC	5200 FC	4200 RF	4200 RC	4200 FC
1000	1000	1000	1000	1000
●	●	●	●	●
○	○	○	○	○
2 single-acting and 1 open return line	2 single-acting and 1 open return line	2 single-acting and 1 open return line	2 single-acting and 1 open return line	2 single-acting and 1 open return line
2.35	2.35	2.35	2.35	2.35
2.15	2.15	2.15	2.15	2.15
5	5	5	5	5
●	●	●	●	●
●	●	●	●	●
○	○	–	–	–
ROTO CUT	FINE CUT	ROTO FEED	ROTO CUT	FINE CUT
25	51	–	25	51
●	●	–	○	●
25, 13, 12, 6, 0	51, 26, 13, 12, 0 / 51, 26, 25, 13, 0	–	25, 13, 12, 6, 0	51, 26, 13, 12, 0
●	●	–	●	●
●	●	–	–	–
–	–	●	●	●
56	56	51	51	51
200	200	200	200	200
●	●	○	○	○
●	●	○	●	●
○	○	○	○	○
○	○	○	○	○
3.85	3.85	3.45	3.45	3.45
1.20	1.20	1.20	1.20	1.20
0.70	0.70	0.70	0.70	0.70
0.50-3.00	0.50-3.00	0.50-3.00	0.50-3.00	0.50-3.00
●	●	●	●	●
○	○	○	○	○
●	●	●	●	●
○	○	○	○	○
○	○	○	○	○
6	6	6	6	6
○	○	○	○	○
24 x 11.5 kg	24 x 11.5 kg	24 x 11.5 kg	24 x 11.5 kg	24 x 11.5 kg
●	●	●	●	●
–	–	–	–	–
○	○	–	–	–
●	●	●	●	●
○	○	○	○	○
○	○	○	○	○
2.89-2.99	2.89-2.99	2.84-2.99	2.84-2.99	2.84-2.99
3.08-3.15	3.08-3.15	3.10-3.17	3.10-3.17	3.10-3.17
8.1	8.1	8.1	8.1	8.1
9.32	9.32	9.32	9.32	9.32
8700-12500	8700-12500	9250-11900	9250-11900	9250-11900

CLAAS continually develops its products to meet customer requirements. This means that all products are subject to change without notice. All descriptions and specifications in this brochure should be considered approximate and may include optional equipment that is not part of the standard specifications. This brochure is designed for worldwide use. Please refer to your nearest CLAAS dealer and their price list for local specification details. Some protective panels may have been removed for photographic purposes in order to present functions clearly. To avoid any risk of danger, never remove these protective panels yourself. In this respect, please refer to the relevant instructions in the operator's manual.

● Standard ○ Optional □ Available – Unavailable



# Growing together.

Everything we do is focused on you, our customers. We understand your daily challenges. Together with you, we develop agricultural technology that enables you to farm successfully and sustainably, now and in the future. Our digital solutions simplify complex processes and make your work so much more convenient. We want to make you the best in your field.



CLAAS KGaA mbH  
Mühlenwinkel 1  
33428 Harsewinkel  
Deutschland  
Tel. +49 5247 12-0  
[claas.com](http://claas.com)