

Fits your farm.

The TRION 740.



The TRION 740.

Fits your farm.

Our passion for building combines dates back to 1936, and since then we have continuously shaped the history of harvesting technology. Indeed, no other company has played such a significant role as CLAAS in the development and innovation of today's combine harvesters. But there is more to what we do than advancing technology – we understand the needs of our customers. Much of what farmers and contractors tell us drives our development process to ensure our products fit the needs of their businesses. The demands of our changing world are also constantly driving us forward.

These drivers have made us what we are today: the business-minded manufacturer for the business-minded ag professional. And the partner of choice for revolutionary harvesting technology. We put our brightest thinking into cutting-edge products that help our customers save more time and make more money. So their businesses are even better than before.

This means the TRION combine is an exciting addition to the CLAAS combine lineup. It is a combination of proven components from over 25,000 previous CLAAS combines operating around the world and innovations specific to today's harvest conditions. Together, this combination, delivers the reliability and performance you have been asking for in an affordable package. These ideas not only come from our exacting nature and always wanting to improve - they are also the result of our sheer enthusiasm and passion for agriculture. Because we know that, together, this results in an even brighter future for us all.



Cathrina Claas-Mühlhäuser
Chair of the Shareholders' Committee

How do we innovate at CLAAS?

It's simple. By working continuously to make harvesting technology better, faster and more efficient. And, a little different, too.



Designed for *your farm.*

For decades, CLAAS combines have set the standard for throughput and efficiency on farms across North America with the flagship LEXION models. Now the CLAAS lineup grows with the TRION combine. The CLAAS TRION is specifically designed to fit the needs of your farm. Built on a proven chassis, it brings reliability and affordability together while being well equipped like other CLAAS products when it comes to performance. By design it gives your farm business a competitive edge in the right-sized package.

402_{hp}
rated output

341_{bu}
grain tank

3.8_{bu/sec}
unload speed

19_{mph}
transport speed

up to 12
row chopping corn head

<5_{min}
crop changeover from
corn to soybeans

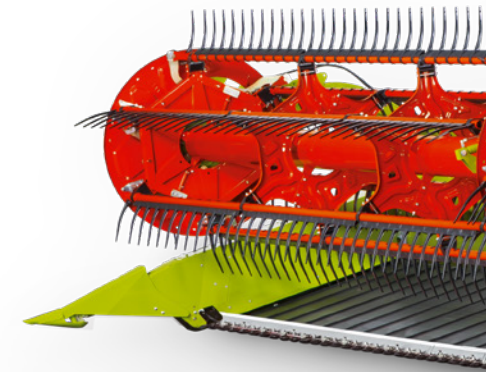



Accelerated Pre-Separation Threshing.

No one ever wants to damage grain in the combine threshing system, and with the CLAAS TRION you fit threshing intensity to your conditions. As the first piece of the hybrid combine, tri-cylinder threshing guides a 56 inch wide crop mat across concave grates. This gentle threshing has been proven in other CLAAS combines around the world. It now proves itself on your farm in the TRION.

Your threshing adjustments can now be made in-line with the changing harvest conditions throughout the day, rather than based on the capability of your machine. High throughput, while protecting the crop and using minimal fuel, gives you yet another competitive advantage.

- 1 1:1 feederhouse to threshing system width means crop isn't folded on itself before threshing, requiring less horsepower.
- 2 Grates under the APS cylinder let easily threshed grain drop to the cleaning system for gentler crop handling, while allowing more space and power for tougher to thresh grain in the crop mat.
- 3 Pre-concave and main concave sections can be changed for varying crop and conditions as needed.
- 4 Flat rasp bar angle gently threshes grain from the cob or pod.
- 5 When changing from corn to small grains, one of two speed ranges is selected with a quick change valve. Low range 180-450 rpm | High range 330-930 rpm.
- 6 Speed of threshing system is set completely independent of separation system speed.

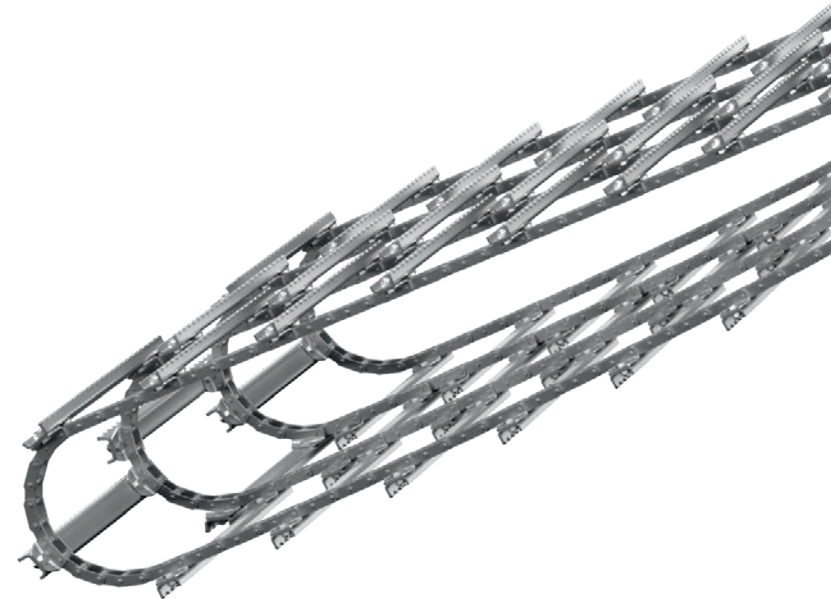

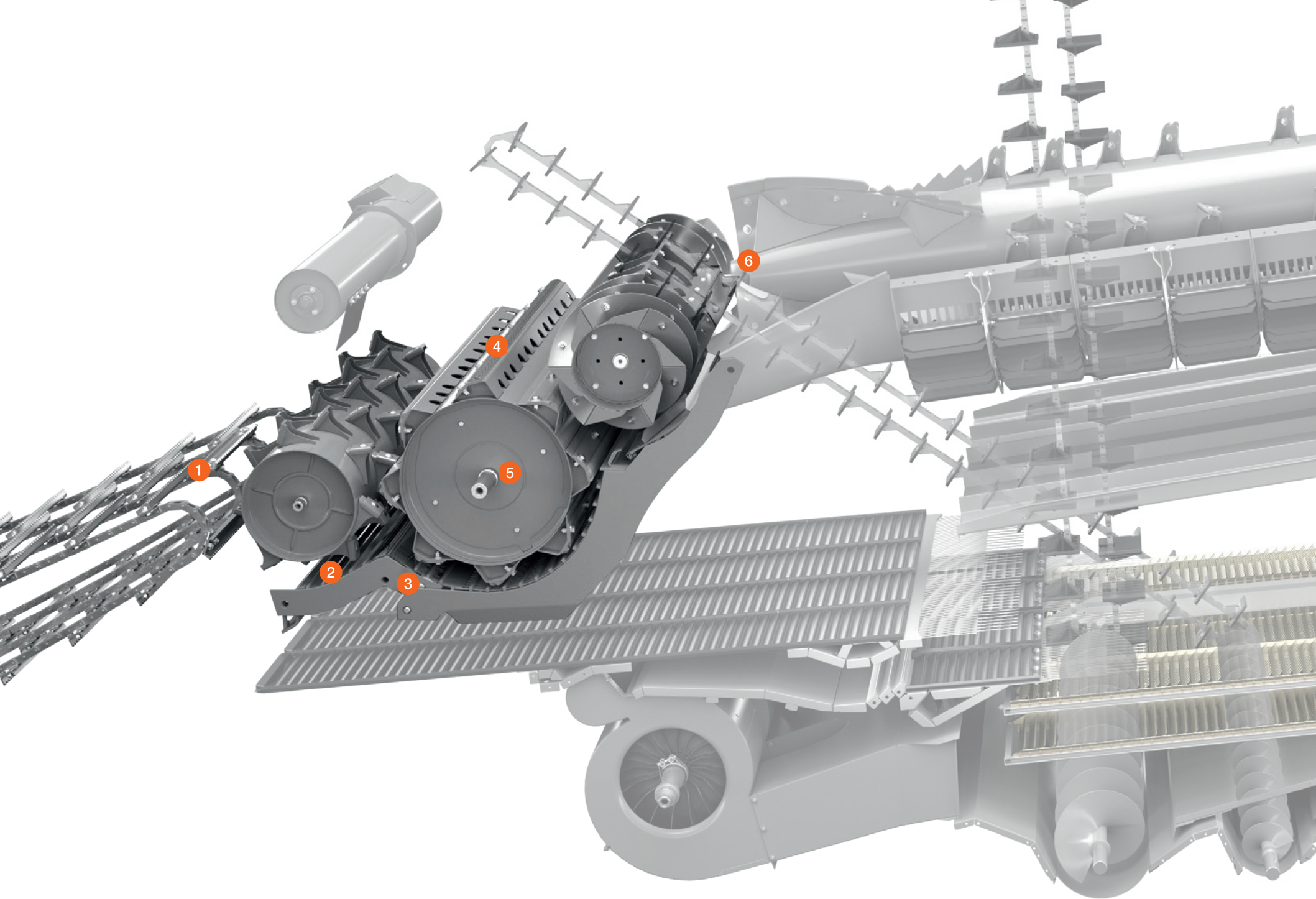

ROTO PLUS Separation.

Grain left in the field behind the combine amounts to lost revenue opportunity. Combine losses even as low as 1.5% amount to 2.7 bushel per acre lost revenue in corn fields yielding 180 bushels per acre. As the second piece of the hybrid combine, the single rotor ensures grain makes it to the grain tank with proven combine losses as low as 0.5%. Only CLAAS brings both cylinder threshing and rotor separation together in one machine for your farm.

Your separation adjustments can now be made to optimize grain retention rather than attempting to balance between threshing intensity and separation speed. This competitive advantage pays dividends harvest after harvest.

- 1 22.5" diameter single rotor fluffs the threshed crop mat to separate grain from material other than grain (MOG) using the 400 to 1,000 rpm speed range.
- 2 180° - rotor grates cover the lower half of the elliptical rotor cage to maximize grain separation.
- 3 Rotor flaps reduce chaff load in dry conditions or can be opened for more separation performance in wet conditions.
- 4 6 rotor grates provide 4,000 in² separation area.
- 5 13.75 feet long rotor dedicated entirely to separating grain from the crop mat.
- 6 Straw is dropped directly into the straw chopper or windrowed without requiring extra horsepower to exit machine.

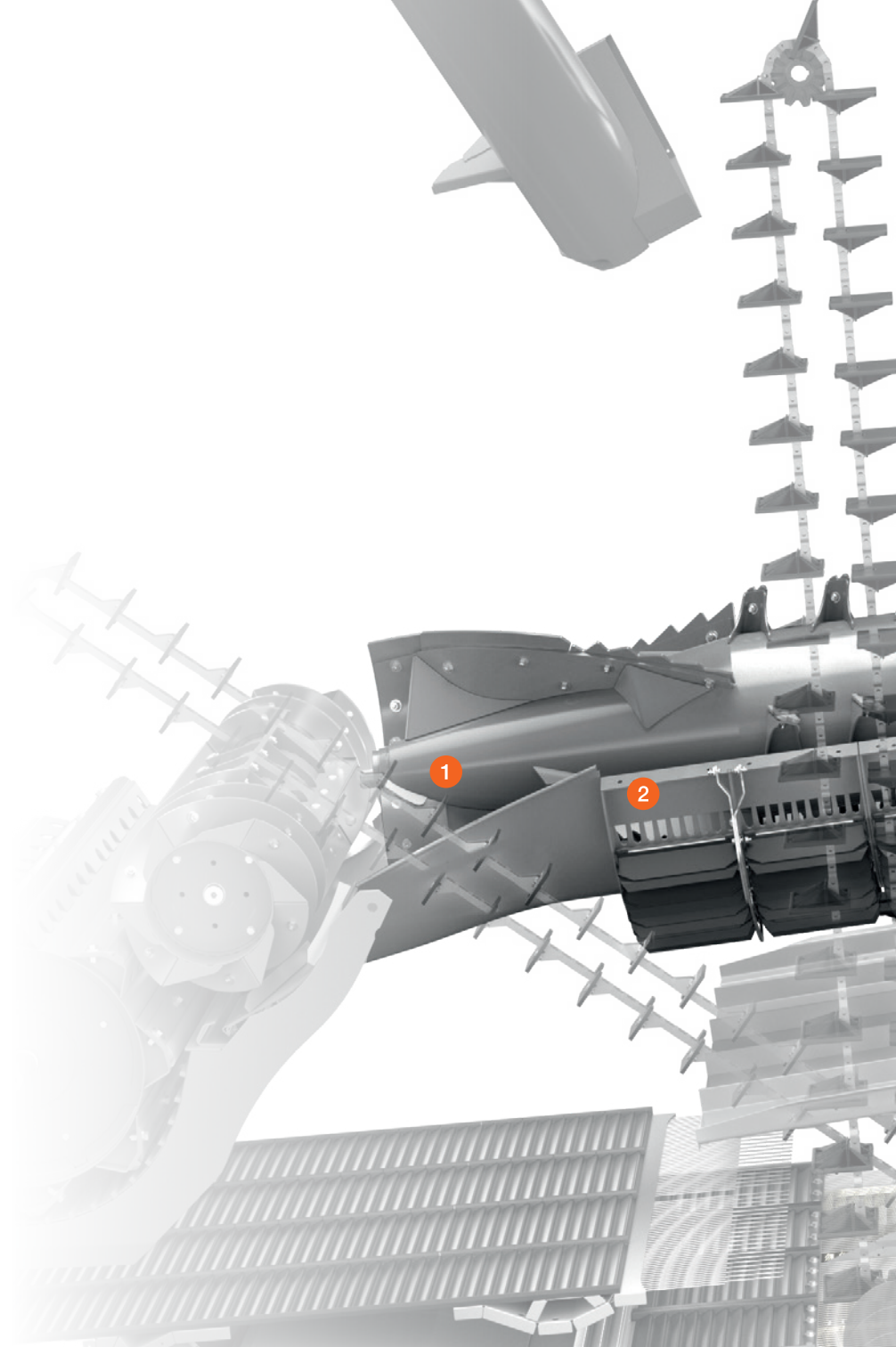

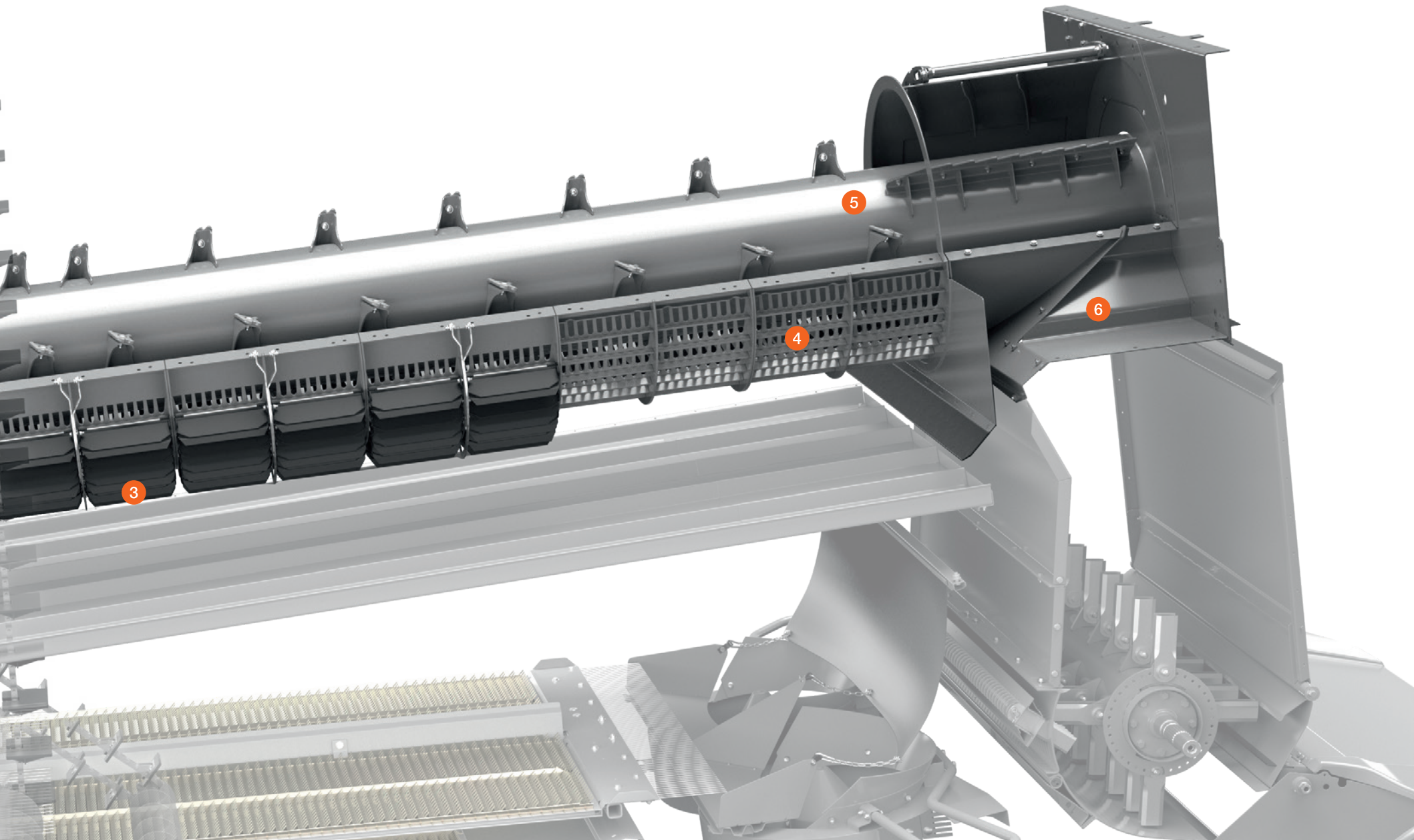

3

4

5

6

JET STREAM Cleaning.

All the threshing and separation capability in the world is irrelevant without a cleaning system to tackle rolling ground and variable crop yields. As the third piece of the hybrid combine, it handles all grain making its way to the grain tank. Straightforward mechanical systems move the crop mat against the slope of a hillside to take advantage of the complete sieve area and limit losses. In the CLAAS TRION this superior cleaning now fits your farm.

Your grain tank is now filled with gently threshed, thoroughly separated, and meticulously cleaned grain. Achieving high grain quality gives you a competitive advantage no matter the final destination of your harvested crop.

- 1 Returns are spread evenly across threshing system, saving power and adjustment time compared to the competition.
- 2 Shaking preparation pan stratifies all grain and chaff.
- 3 6 turbine fans provide 2 air streams across the complete 56 inches wide cleaning system, one with high pressure and low volume, the other with low pressure and high volume.
- 4 6120 bu/hr rated clean grain system allows high throughput in high yield conditions.
- 5 Rotor return pan moves everything to the front, all grain and chaff sees the entire sieve length.
- 6 Automatic 3D side slope compensation shakes crop across the entire upper sieve area without needing any driver input.

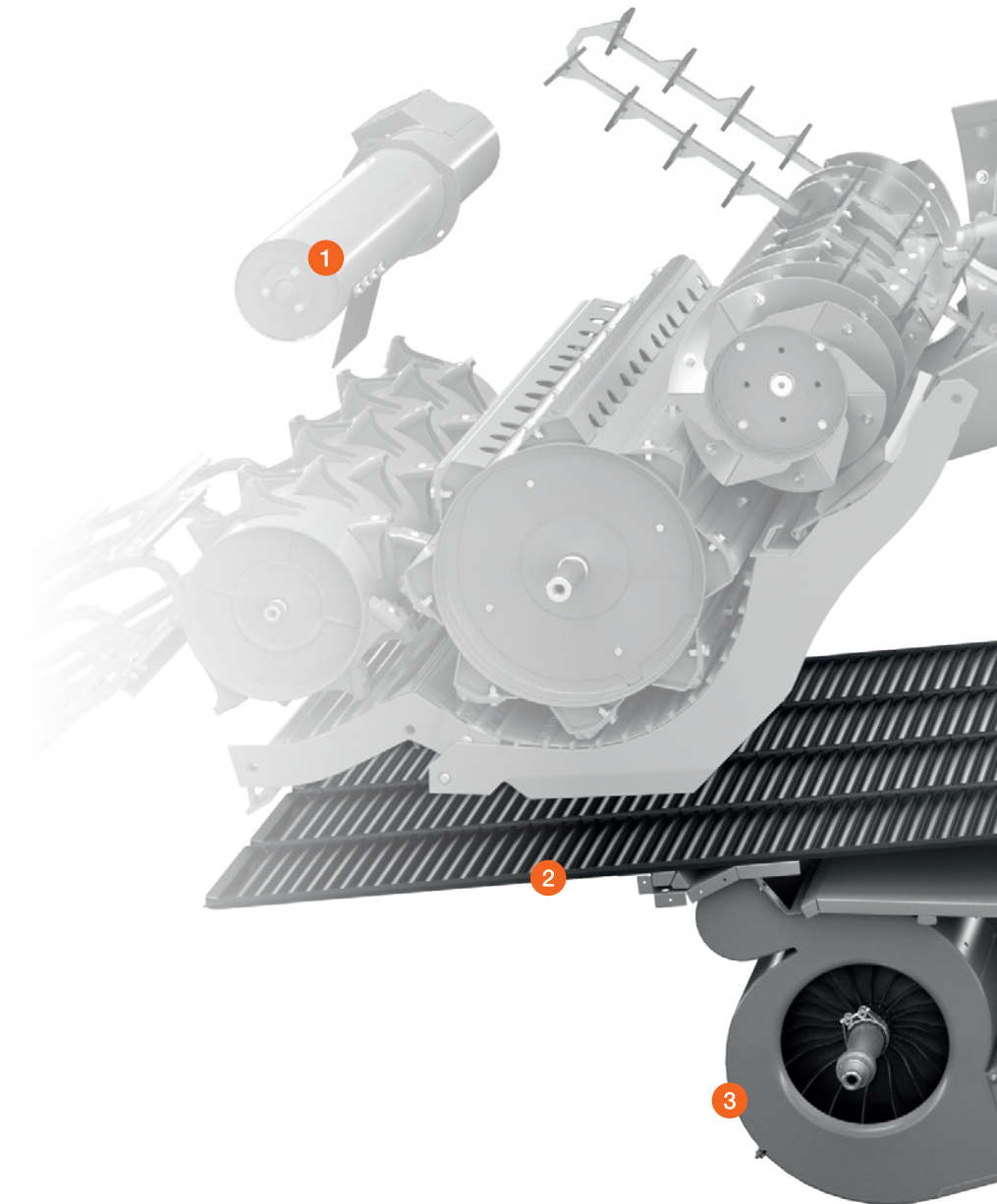

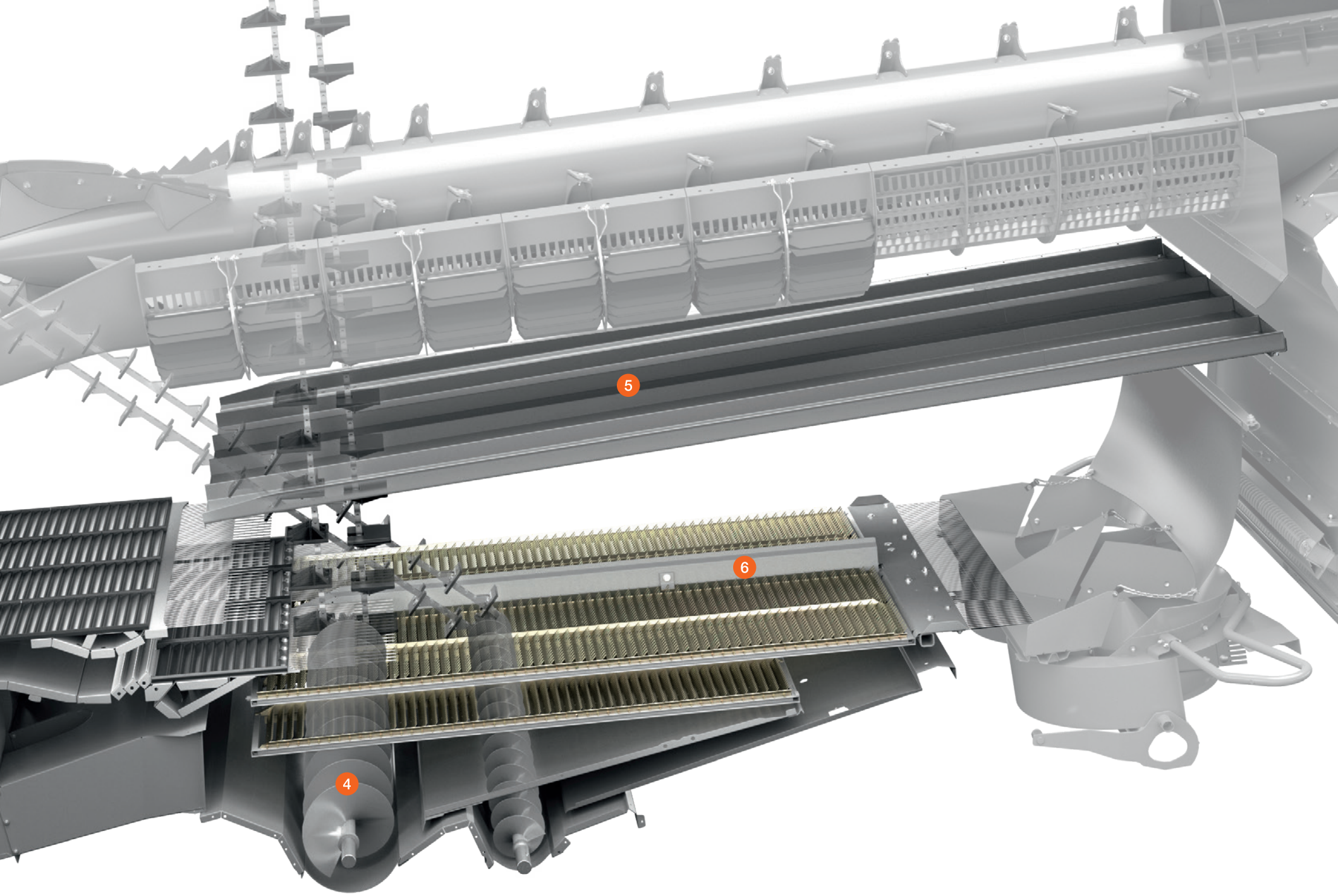

For those who know the window isn't getting any wider.

We roll up our sleeves every harvest season to support the success of CLAAS owners around the world. For the CLAAS TRION 740 combine, that means over five years of field testing across three continents were invested to prove its reliability. It is a blend of new innovations and proven components used in over 25,000 previous CLAAS combines. The validation investment establishes the TRION with the reliability you have been asking for.

Quickly get the day started to harvest more using the centralized grease banks with extended greasing intervals. Strategic filter location reduces filter changes and minimizes the time spent idle each day.

DAILY MAINTENANCE

	CLAAS TRION 740	JOHN DEERE S SERIES	CASE IH 250 SERIES
Grease Zerks Under 10 Hours	0	Up to 7	0
Daily Greasing Time (min)	0	15	0
Daily Air Filter Maintenance (min)	0	15	15
Daily Machine Clean Off Time (min)	45	45	45
Daily Maintenance Time (min)	45	75	60





When it's time to run, your equipment and the support behind it needs to be ready to go. Our parts centers boast some of the best fill rates in the industry with a focus on dependability, resulting in a 90 percent customer satisfaction for us.

MACHINE SUPPORT

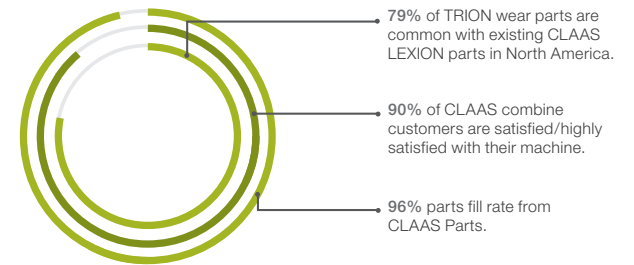

Today's harvesting conditions and yields require a combine equipped to stand up to large quantities of abrasive grain. That's why augers, elevator boots, wear plates, and other components are fitted from the factory with extended wear parts. More than half of the crop flow is designed with this unique material for the utmost durability season after season.

EXTENDED WEAR COMPONENTS



At the end of the day you'll have more to show for it.

The CLAAS TRION combine is designed to save you time and money, giving your farm a competitive edge. A simple belt drive-line keeps power requirements low. Side slope compensation keeps grain loss to a minimum. Benefits like these put more dollars in your pocket and keep them there. Your neighbors may not notice this about your TRION combine, but you certainly will.

Not all crops require rearranging the threshing grates on the CLAAS TRION. In conditions where a changeover is needed, one person can quickly switch grates and get back to harvesting. This is comparatively easier and less costly than similarly equipped competitors.

REARRANGEMENT TIME + LABOR

		CLAAS TRION 740	JOHN DEERE S SERIES	CASE IH 250 SERIES
Grate Changeover	minutes	15	60	45
People Required	number	1	2	1
Lost Productivity	acres	4.55	18.18	13.64
TRION Advantage	acres	-	13.63	9.09





Unique to CLAAS combines is the 3D slope compensation system, factory fitted to every TRION. Without any driver input, the upper sieve shakes grain away from the downhill slope. This maximizes capacity of the cleaning system when harvesting in rolling terrain to capture the most of your hard earned crop. All of this is accomplished without costly accessories or time intensive rearrangements.

CLEANING SYSTEM SLOPE COMPENSATION



Power distribution throughout the machine is more efficient with direct belt drives than using multiple driveshafts and gearboxes like competitive machines. You save money on fuel by harvesting more with less. Powered by a Cummins L9 8.9 liter engine, the CLAAS TRION is one of the most fuel conscious combines on the market.

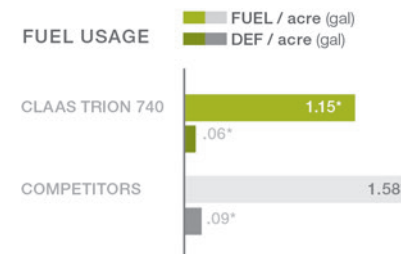

* Derived from internal studies on class 7 combines.

Farming is a competition. This is how you win.

The decades old crop flow pattern used in competitors prevalent combines holds your business victim to average harvesting results season after season. A CLAAS TRION combine fits the needs of your farm today with capacity and precision for modern crop yields that press the constraints of your current machine. All of this is accomplished with unmatched grain handling of high value crops like soybeans.

The TRION is well equipped like other CLAAS products when it comes to performance. Higher throughput than similarly sized competitors allows you to get more crop harvested per day and to finish harvest quicker.

AVERAGE ACRES PER HOUR

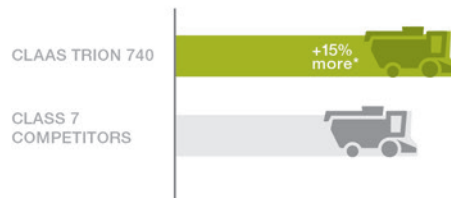

* Derived from internal studies on class 7 combines.





Very limited grain loss at high throughput keeps more grain in the combine than the competition. Independent threshing and separation systems allow you to fine tune performance for any harvest condition, retaining more of your hard-earned crop.

GRAIN LOSS COMPARISON



* Derived from internal studies on class 7 combines.

When harvesting soybeans, the CLAAS TRION doesn't compromise on grain quality. The gentle, cylinder threshing system and separation rotor does an excellent job of keeping the seed coat intact at typical harvest speeds.

SOYBEAN SPLITS @ 4 MPH

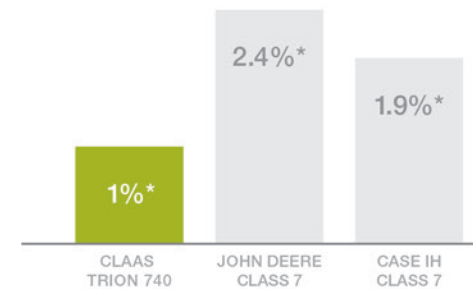

* Derived from internal studies on class 7 combines.

Specifications

TRION		740	740 TERRA TRAC
APS HYBRID threshing system			
Threshing system width	in (mm)	56 (1420)	56 (1420)
Accelerated pre separation drum diameter	in (mm)	18 (450)	18 (450)
Threshing drum diameter	in (mm)	24 (600)	24 (600)
Feed impeller diameter	in (mm)	15 (382)	15 (382)
ROTO PLUS separation system			
ROTO PLUS Rotor	no.	1	1
Rotor length	ft (m)	13.75 (4.2)	13.75 (4.2)
Rotor diameter	in (mm)	22.5 (572)	22.5 (572)
Rotor grate area	degrees	180	180
Rotor grates	no.	6	6
Hydraulic rotor covers	no.	4	4
JET STREAM cleaning system			
JET STREAM turbine fans	no.	6	6
3D-cleaning system		●	●
Sieve side-slope compensation	percent	20	20
Grain tank			
Capacity	bu (l)	341 (12,000)	341 (12,000)
Unloading rate	bu/s (l/s)	3.8 (130)	3.8 (130)
Tier IV engine			
Manufacturer / Type		Cummins L9	Cummins L9
Cylinders / displacement	no. / l	6 / 8.9	6 / 8.9
Rated power	hp (kW)	402 (300)	402 (320)
Max power	hp (kW)	430 (320)	430 (320)
Ground drive			
Top transport speed	mph (km/h)	19 (30)	19 (30)
Front axle		Wheels	TERRA TRAC
Differential lock		●	–
Powered rear axle		○	○
Operator assistance systems			
CEMOS AUTO CROP FLOW		●	●
CEMOS 4D CLEANING		○	○
Full CEMOS autonomous machine automation		○	○
Data management			
TELEMATICS		●	●
Remote Service		●	●
Open steering interface prepared		●	●
Ag Leader steering system		○	○
Ag Leader prepared		○	○
Trimble prepared		○	○

● Standard ○ Optional – Not available





Customer Care Program

MAXI CARE.

Maximize uptime and manage your cost of ownership with CLAAS MAXI CARE service products. Talk to your CLAAS dealer about a customized service package for your machine.

- Up to 10 years maintenance warranty
- Annual pre-harvest inspection
- Deductible as low as \$0





CLAAS of America Inc.
8401 South 132nd Street
Omaha, NE 68138
Phone +1 402 861-1000

[claas.com](https://www.claas.com)

CL99881062 / 11/22

©2022 CLAAS of America Inc. All descriptions and specifications should be considered approximate and may include optional equipment. In certain cases, protective panels have been removed to show detail. To avoid risk of injury, never remove these panels yourself. Please refer to operators manual for instructions. Product and specifications subject to change without notice.