



Combine harvesters

LEXION

6800 6700



Campaign performance
like never before.

The LEXION.

When you harvest a whole year's crop, you need to be able to rely on the perfect interaction of the entire machine chain. The combine harvester in your fleet has a key role to play. It is the decisive factor for reliable seasonal performance, year after year.

The optimised LEXION models are the most productive machines on the market – measured in terms of harvested area or tonnes per year. And they bring their strengths precisely when you really need maximum performance – even in unfavourable conditions. You save time and fuel and are more productive than ever before. As the key player in your harvest, the LEXION brings in your crop on time, economically and reliably.



Reduce your fuel consumption and increase your yield.

You can only operate profitably when every machine in your fleet is working as efficiently as possible. Top performance and maximum efficiency are the most important criteria for success, especially when contending with adverse conditions. The top LEXION models impress with fuel consumption of about 1 litre per tonne at the highest throughput and can deliver their top performance exactly when it is really needed. Discover the new benchmark for efficiency.



Increase your productivity in comfort with the new LEXION cab.

The final push of the harvesting season is when you need to be as focused and relaxed as possible. This is why everything in the LEXION's new cab is designed for comfort. It is noticeably more spacious at head, shoulder and leg level and features a completely new air conditioning system. The intelligent control concept allows you to exploit the full potential of the machine while the bright CEBIS terminal provides you with razor-sharp information so that you can pick up all the relevant data at a single glance. Make yourself comfortable and increase your productivity.

Optimum performance, even when time is at a premium.

A tightly timed harvest doesn't mean that you have to compromise on the quality of the results. With the right assistance, you can work accurately, even when time is at a premium. CEMOS AUTO HEADER is the first assistance system that automatically adjusts cutterbar settings, such as table length and reel position, to the prevailing harvesting conditions. This results in a consistent crop flow and improves the performance and efficiency of the threshing unit as well as the separation and cleaning functions. By supporting the automation of the threshing process, this system offers you an additional level of comfort and convenience. Experience precise work quality delivered with no more effort than the touch of a button.



Harvesting at its best.

The CLAAS LEXION.

Efficiency	6
Precision	8
Comfort	10
Reliability	12

Front attachment detection function

Feeder housing	14
	16

Crop flow

APS SYNFLOW WALKER	18
Threshing unit	20
Straw walker	22
Crop cleaning	24
Grain collection	26
Chaff and straw spreading	28
	30

CLAAS POWER SYSTEMS

DYNAMIC POWER	32
DYNAMIC COOLING	34
Ground drive and drive system	36
TERRA TRAC	38
	40

Cab

Comfort cab	42
Control concept	44
	46

Digitalisation

CEMOS AUTOMATIC	48
	50

Operator assistance systems

Steering systems	52
Data management	56
	58

Maintenance	60
CLAAS Service & Parts	64
Technology in detail	66
Advantages	68
Technical data	71

Efficient
like never before.

APS SYNFLOW WALKER
increases throughput and straw quality.
Page 20

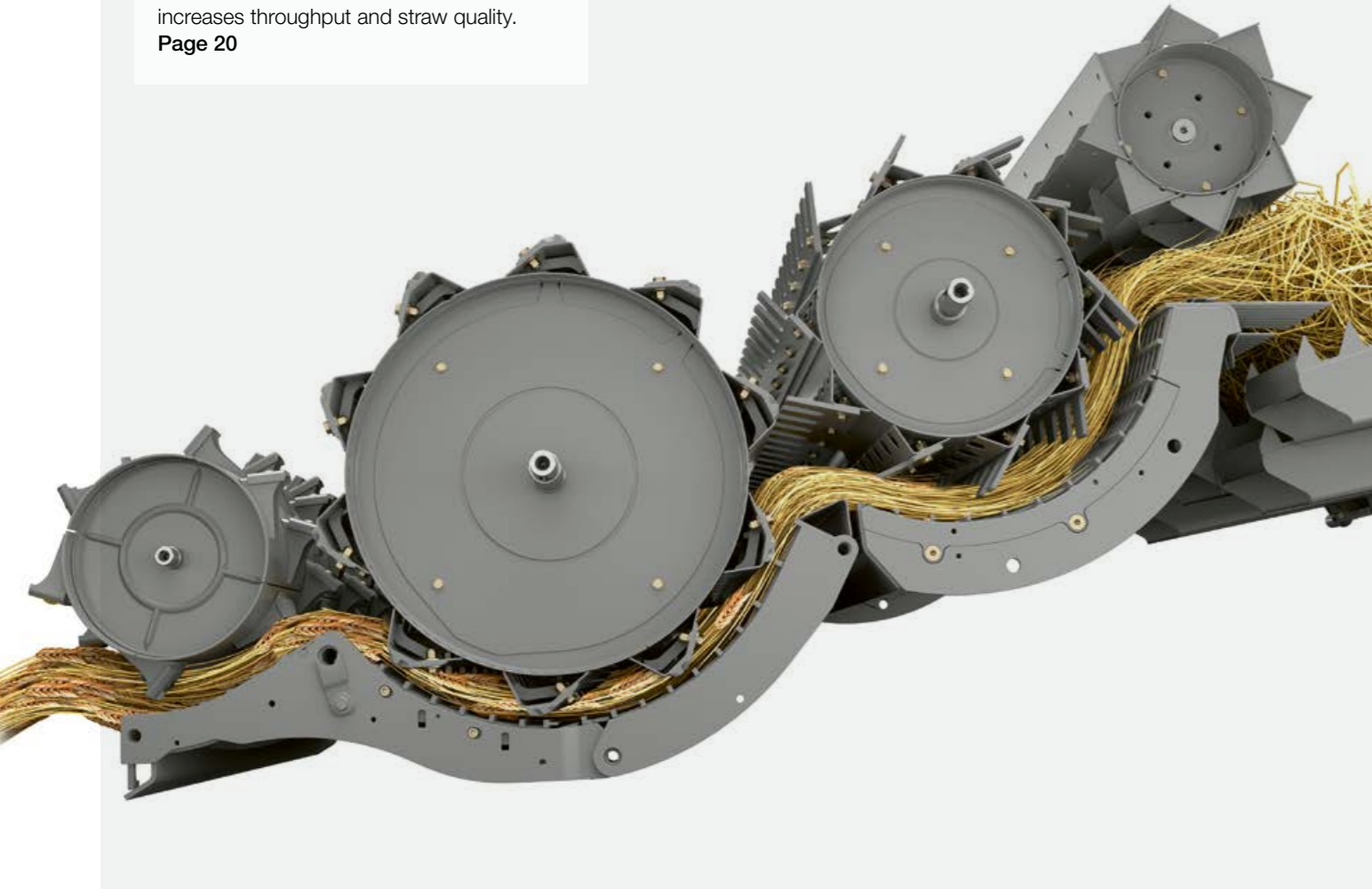

40 km/h
gets you there quickly.
Page 38



Increase your productivity.

Impressively powerful performance translates into profitable efficiency. The LEXION delivers its top performance precisely when your operators really need it. This means that you save time and money while benefiting from exceptional productivity.

Efficiency means success:

- APS SYNFLOW WALKER threshing system with maximum separation performance.
- Large threshing and separator drums with a straight crop flow.
- Parallel threshing concave adjustment with overload protection.
- Grain tank for up to 13,500 l and 180 l/s unloading rate.
- DYNAMIC POWER intelligent engine management.
- DYNAMIC COOLING in all models.
- JET STREAM grain cleaning as standard.
- 40 km/h top speed for wheeled machine and TERRA TRAC version.
- Cutterbars up to 12.30 m.

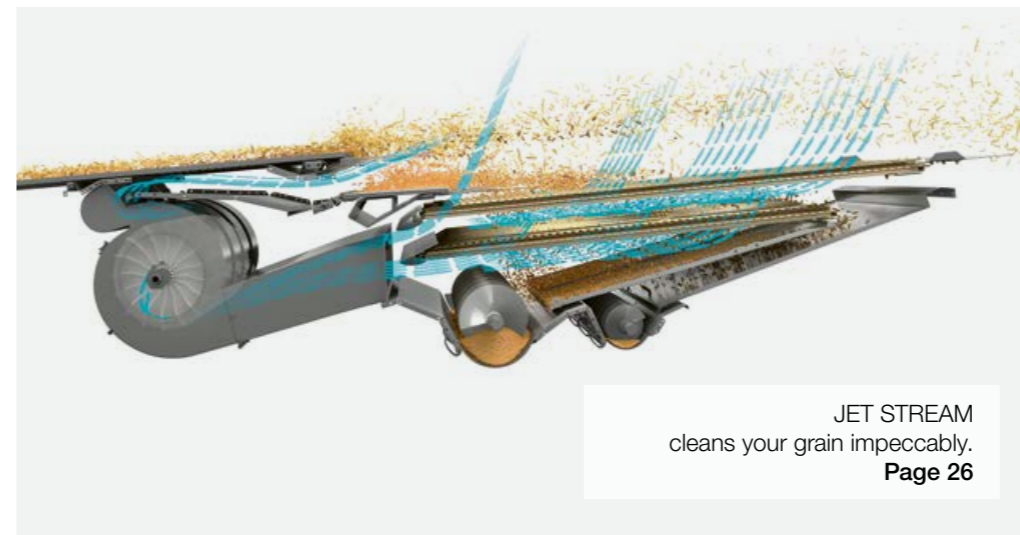

JET STREAM
cleans your grain impeccably.
Page 26

13,500 litres
unloaded in 75 seconds.
Page 28



DYNAMIC COOLING
provides cooling as required.
Page 36



DYNAMIC POWER
saves up to 10% of fuel.
Page 34



Discover how much
it can do for you.

Precise
like never before.

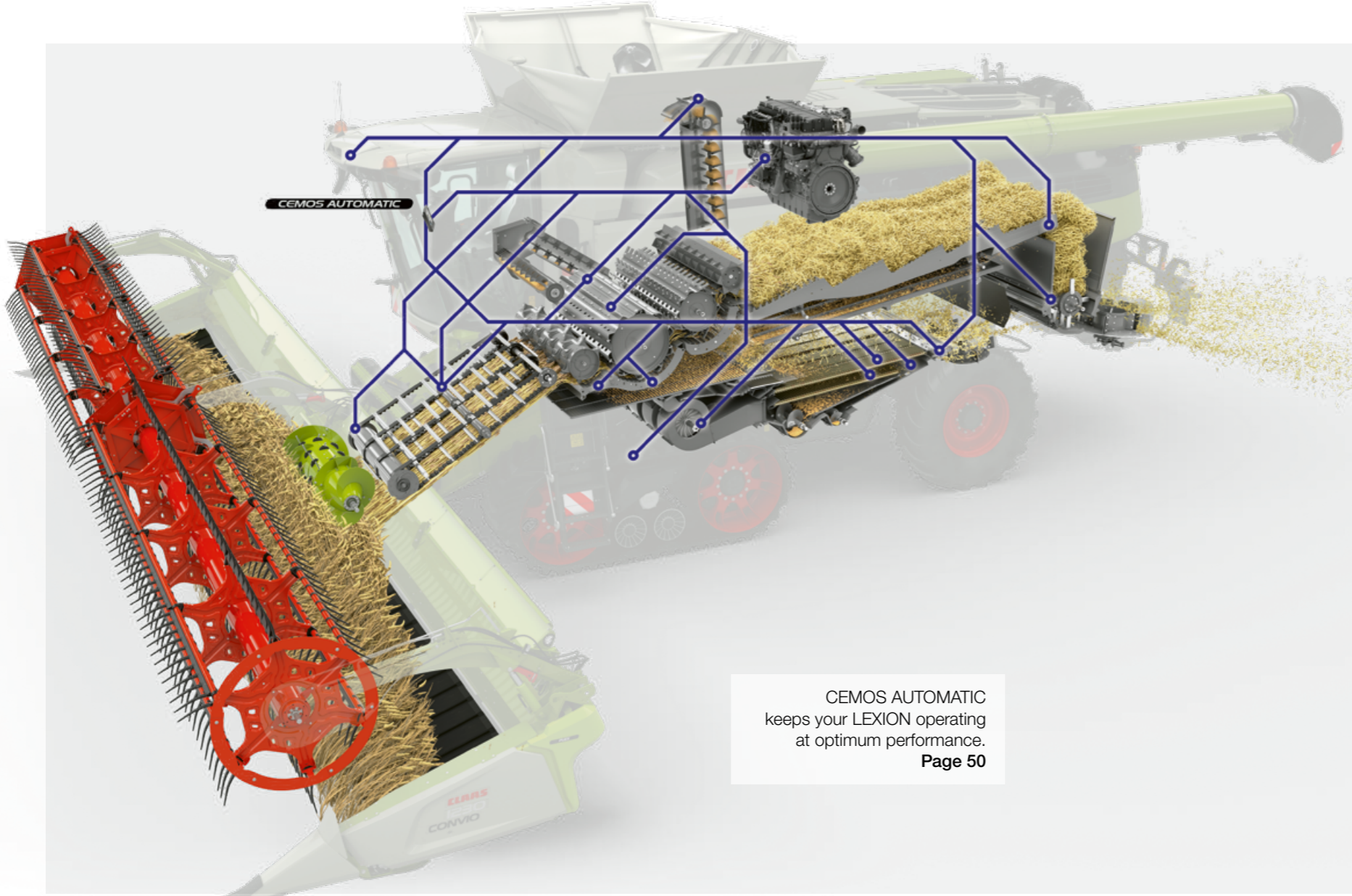

CEMOS AUTOMATIC
keeps your LEXION operating
at optimum performance.
Page 50



AUTO SLOPE
reduces your workload
on slopes.
Page 52



FIELD SCANNER
gives you a free hand.
Page 56



Make use of its intelligence.

To increase your campaign performance, you need a combine harvester that is able to think for itself and think ahead. In the LEXION, self-learning assistance systems, such as CEMOS AUTOMATIC, are working in the background to support the operator during every minute of the harvesting process.

Precision means profitability.

- CEMOS AUTOMATIC continuously optimises threshing unit, cleaning system and crop flow.
- CEMOS AUTO THRESHING can now also adjust the threshing concave bar and flap.
- CEMOS AUTO CHOPPING optimises straw management and fuel consumption.
- The FIELD SCANNER detects the edge of the crop and recognises tramlines.
- TELEMATICS documents job data, tracks and yield data and transmits them to the cloud.
- CEMOS AUTO HEADER actively controls the position of the reel and the VARIO cutterbar table.
- CEMOS CONNECT ensures that all the combine harvesters in a fleet operate with the same efficient settings.



CEMOS AUTO CHOPPING
was awarded the
DLG Silver Medal in 2019.
Page 30



The future
is connected.
Page 58

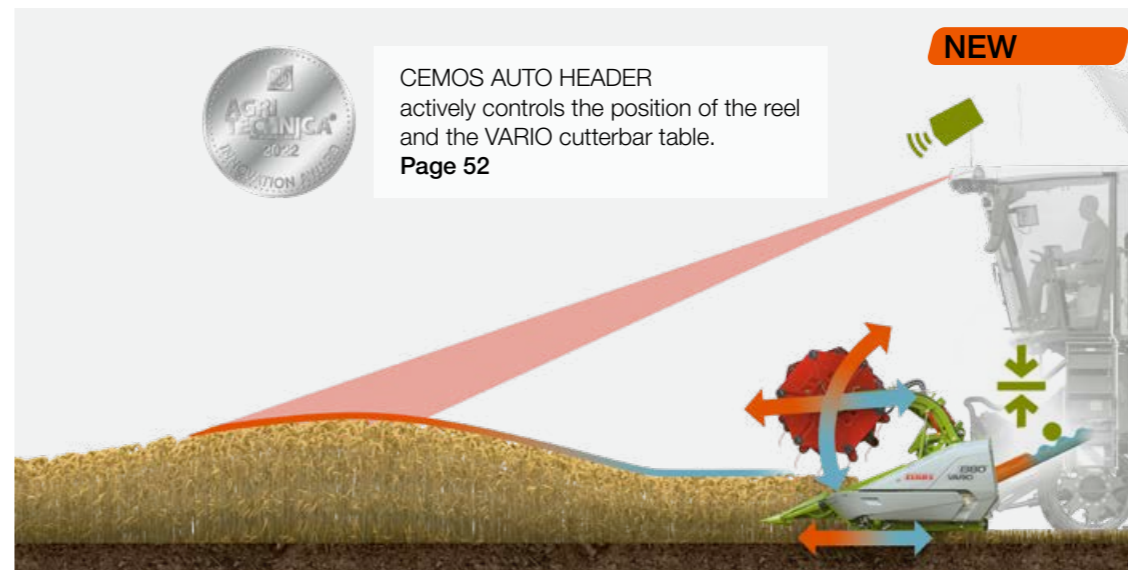

CEMOS AUTO HEADER
actively controls the position of the reel
and the VARIO cutterbar table.
Page 52

NEW



Discover how
precision gives you a
greater advantage.

Comfort
like never before.

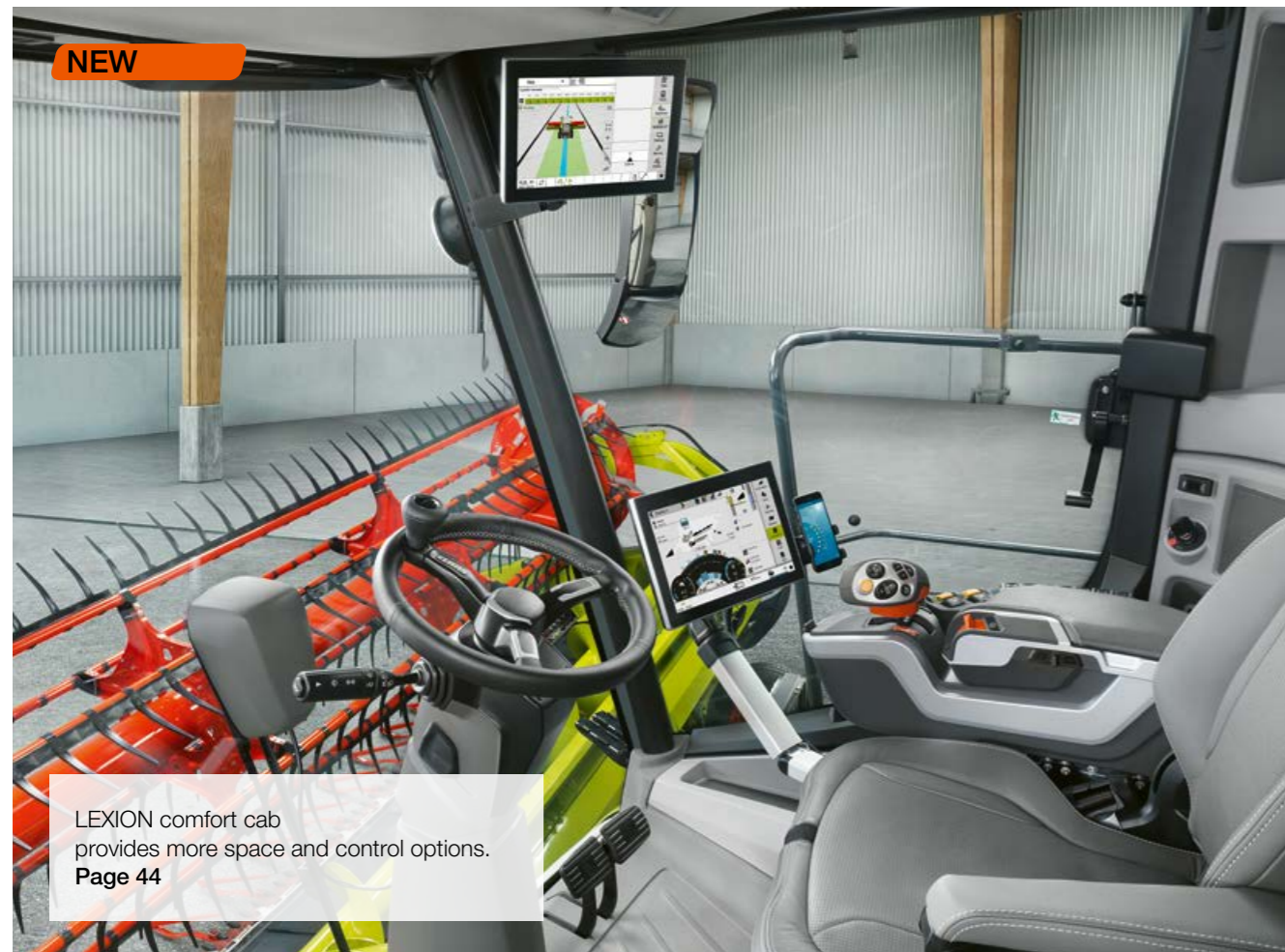

NEW

LEXION comfort cab provides more space and control options. **Page 44**

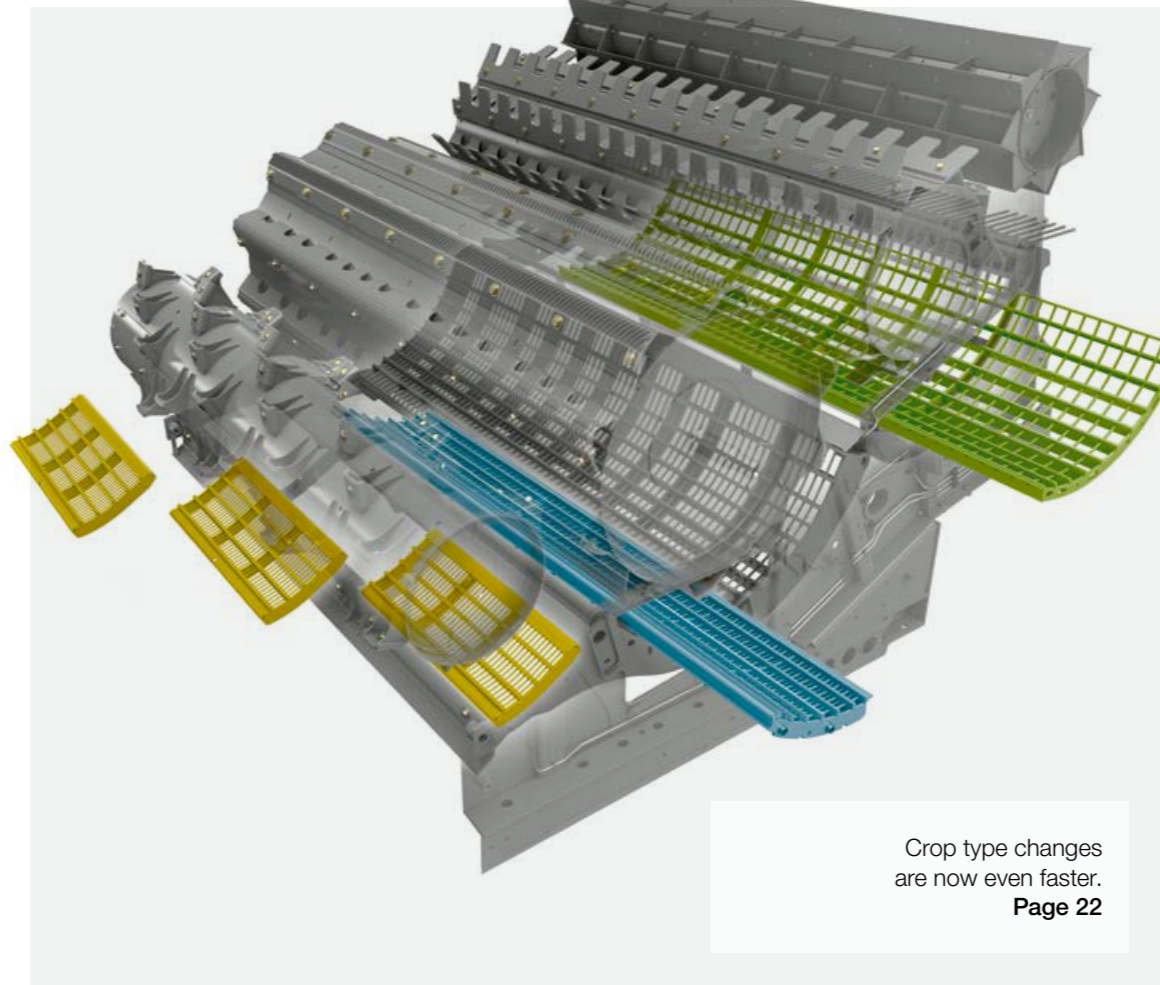

Crop type changes are now even faster. **Page 22**



Harvest for longer.

The LEXION makes your work in the field easier, or even does away with some of your tasks altogether. Its functions offer operators a maximum level of support so that they remain focused and productive – regardless of how early they start work or how late they stop.

Comfort improves performance:

- CEBIS terminal with touchscreen and slide controllers for CEMOS AUTOMATIC.
- Fast crop type changes requiring only a few, simple actions.
- Larger grain tank inspection window for fast crop inspection.
- Unloading tube with 105° pivot angle.
- Air conditioning with all-new airflow system keeps your head cool and your feet warm.
- Large storage compartments in the B-pillar and a cool box under the instructor's seat.
- Digital radio with hands-free function.
- LED work lights and maintenance lighting available in a number of different versions and configurations.



NEW

The pivoting spout on the grain tank unloading tube directs the stream precisely. **Page 28**

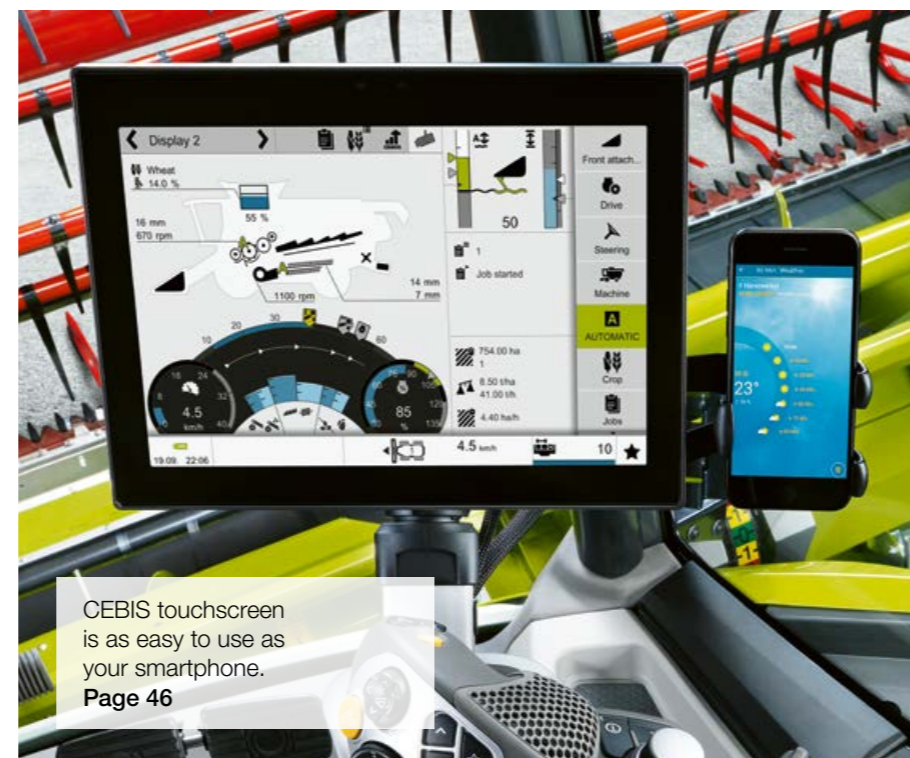

CEBIS touchscreen is as easy to use as your smartphone. **Page 46**



Operation of the CMOTION multifunction lever is intuitive. **Page 46**



Discover why comfort is an indispensable factor for successful harvesting. **Scan me.**

Reliable
like never before.

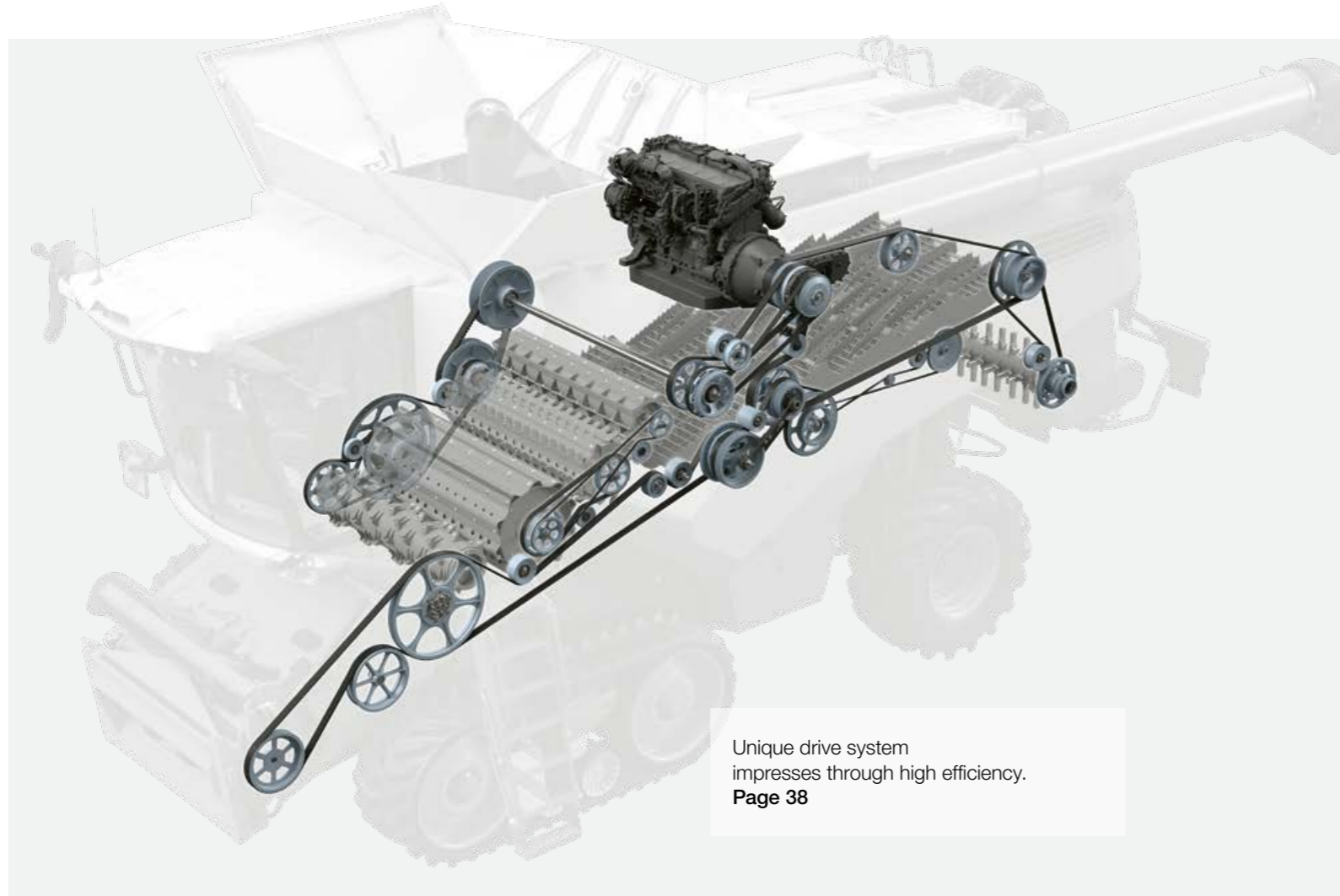

Unique drive system impresses through high efficiency.
Page 38



All maintenance points can be accessed very easily.
Page 60



You can count on it.

When a combine harvester sets the standards for power and performance, it should do the same with regard to endurance and reliability, too. The intelligent drive system of the LEXION is one of the many factors which keep maintenance requirements low and operating reliability high.



PREMIUM LINE components: extra wear resistance and a very long service life.
Page 62

Reassuringly reliable:

- Central lubrication system for all lubrication points, including the variators.
- Integrated overload protection to avoid blockages in the threshing unit.
- More powerful dust extraction with enlarged cross-section.
- Belt conveyors for V and HP feeder housing with twice the service life of a feeder chain.
- Lowered floor plate in feeder housing for higher throughput.
- Flexible MAXI CARE service products for greater operational reliability.
- Parts subject to heavy loads in wear-resistant PREMIUM LINE quality.
- Remote Service for fast and easy maintenance and service support.

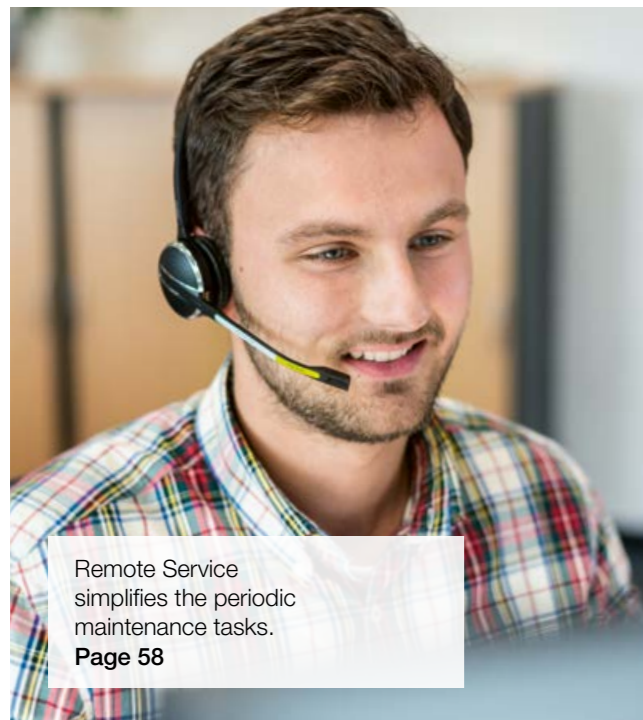

Remote Service simplifies the periodic maintenance tasks.
Page 58



MAXI CARE keeps repair and breakdown risks to a minimum.
Page 64



Belt conveyor in feeder housing for smoother running and a longer service life.
Page 16



Get to know the features that make the LEXION a model of reliability.

It detects the front attachments,
so you have less to do.

Excellent cutting right from the start.

With the right cutterbar, you can harvest effectively and extremely productively right from the word go. Automatic front attachment detection helps you to get your LEXION ready for action even faster.

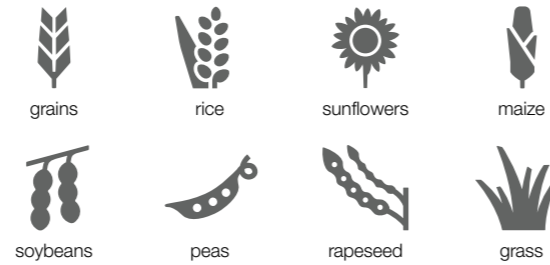

VARIO
1230 / 1080 / 930 / 770 /
680 / 620 / 560 / 500

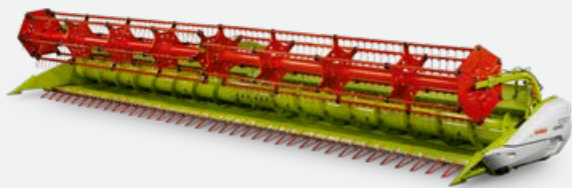

CERIO
930 / 770 / 680 / 620 / 560

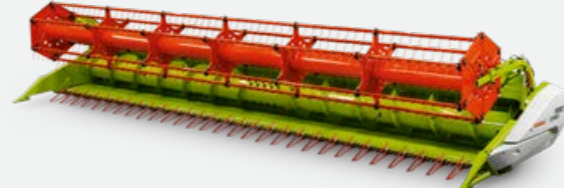

Folding cutterbars
C 540 / 450



CONVIO / CONVIO FLEX
1230 / 1080 / 930 / 770



MAFLEX
930 / 770 / 680 / 620 / 560

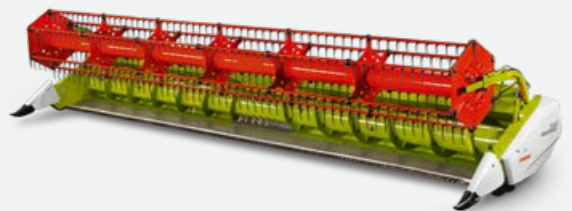

CORIO / CORIO CONSPEED
1275 / 1270 / 890 / 880 / 875 / 870 /
675 / 670



SUNSPEED
16-70 / 12-75 / 12-70 / 8-75 / 8-70



SWATH UP
450



Automatic front attachment detection saves time.

The LEXION configures the key parameters automatically. It does this based on the following information it receives from the front attachment module: cutterbar type, working width, number of sections, reel position, parking position and the AUTO CONTOUR set values for working height and hectare counter.

You benefit right from the start.

- The combine harvester is set up quickly for harvesting.
- It is significantly easier to operate.
- The positions of the reel, VARIO cutterbar table and feeder housing are taken into account to rule out the risk of collisions and damage.

AUTO CONTOUR cuts with greater precision.

AUTO CONTOUR adjusts every cutterbar to the terrain precisely. Sensor bands under the cutterbar are deflected by the undulations and trigger the actuation of the corresponding cutterbar rams. The desired cutting height is programmed via CEBIS.

Let us take a weight off your mind.

- AUTO CONTOUR damps and protects the front attachment.
- It makes working with wide cutterbars easier.
- Your operators will appreciate its assistance, especially at night, in laid crops, on side slopes and on stony ground.
- It increases output and makes using the LEXION even more cost-effective.

Choose the right front attachment.
combine-front-attachments.claas.com

Scan me.

The feeder housing is equal to any challenge.

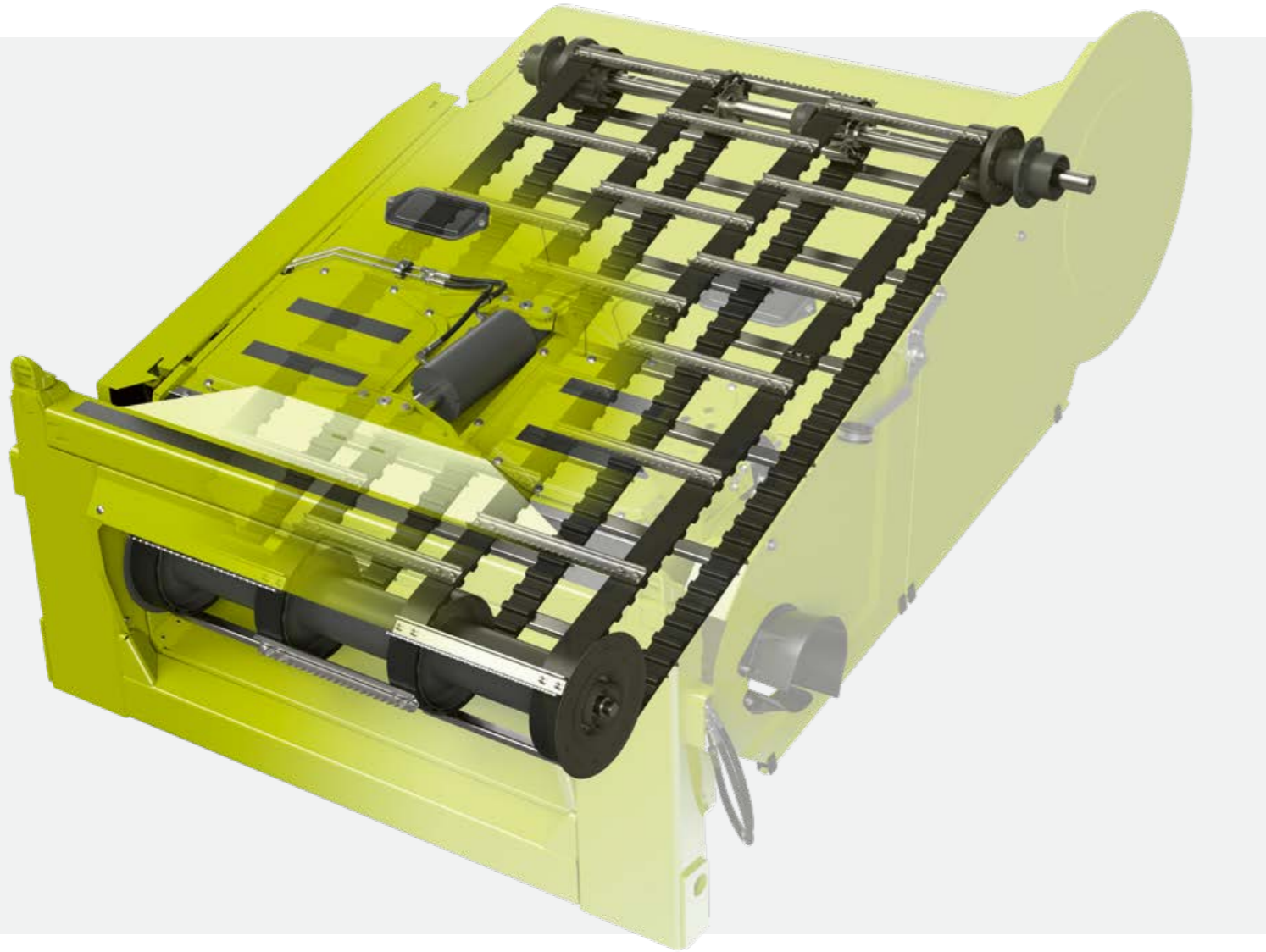

Belt conveyors with twice the service life.

High on resilience, low on maintenance.

As an option, belts can be specified to link the reinforced feeder slats in the V feeder housing and the HP feeder housing. The belt conveyors run noticeably more smoothly and quietly than conventional chain conveyors. They also require less maintenance and are very durable in resisting stones and other foreign objects.

In order to protect the machine, an automatic "soft start" system keeps load peaks at a low level during start-up of the cutterbar and feeder housing. A slipping clutch provides overload protection for the belt conveyors.

A powerful feeder unit makes you more productive.

- Belt conveyors (optional for V and HP feeder housing) are more robust and reliable than chains.
- The dust extraction system with a large cross-section delivers even greater cleaning performance.
- The additional fan on the feeder housing prevents dust deposits.
- You can adjust the height of the feed roller without using tools.
- A lowered floor plate allows you to achieve even higher throughputs.



Feeder housing.

The universal feeder housing with a mechanical tensioning system is available with chain or belt conveyors and with an open or closed guide roller. It is suitable for all cutterbars up to a working width of 12.30 m or for maize pickers up to 9 m.



V feeder housing.

The V feeder housing allows you to carry out fast, mechanical adjustment of the cutting angle. This means that you can harvest laid crops, soybeans and grass-seed with greater ease and with reduced losses as the tendency for the crop to build up is reduced. You can order the V feeder housing ex factory with chain or belt conveyors as well as with an open or closed guide roller.



HP feeder housing.

Using the multifunction lever in the cab, you can perform continuous hydraulic adjustment of the cutting angle of the HP feeder housing from -8° to $+11^\circ$ – and you can do so when running at full speed with the front attachment fitted. You can store a separate cutting angle for each of four cutting heights in CEBIS. In this way, you can respond quickly and conveniently to different crop stands, crops or terrain conditions.



Everything for safe harvesting.

The front attachment brake offers effective protection against foreign objects. In an emergency, you can stop the front attachment immediately via the multifunction lever. Blockages can be cleared by means of protective reversing with high starting torque. The slow intake feeding after reversing avoids load peaks. All functions can be actuated sensitively.

Its process technology has what it takes.

Designed to be taken to the limit.

Feeder housing, threshing system, secondary separation, straw management – you can count on the LEXION's process technology to cope, whatever the conditions may be. This combine harvester has everything it takes to deliver excellent harvest performance. On top of that, it impresses with its intelligent assistance systems that allow you to operate it continuously at its performance limits.

Crop flow at its best.

LEXION operators have always been able to call on an outstandingly capable machine with top performance and efficiency in its DNA. This will continue to be the case in the future.

- The APS SYNFLOW WALKER threshing unit can cope with all crop types. CEMOS AUTO THRESHING applies the appropriate settings, automatically and precisely.
- Clean grain is worth real money. JET STREAM cleans the grain intensively.
- AUTO CONTOUR reduces your workload in every job. The LEXION guides the cutterbar precisely over the ground.
- Keep downtime to a minimum. The front attachment brake keeps foreign objects away from the threshing unit.
- Avoid load peaks. The slow intake feeding after reversing can be controlled intuitively.
- You can use the standard feeder universally with all available front attachments.
- Adjust the cutting angle to your harvest conditions. It is adjusted mechanically in the V feeder housing.
- Harvest all crop types without interruption. With the HP feeder housing, you adjust the cutting angle conveniently from the cab.
- Its straw management is excellent. Even when the machine is operating in strong crosswinds, handling high straw volumes or negotiating side slopes, the power spreader always deposits the straw precisely.



APS SYNFLOW WALKER accelerates your harvest.



Experience perfect
crop flow in action.

Scan me.

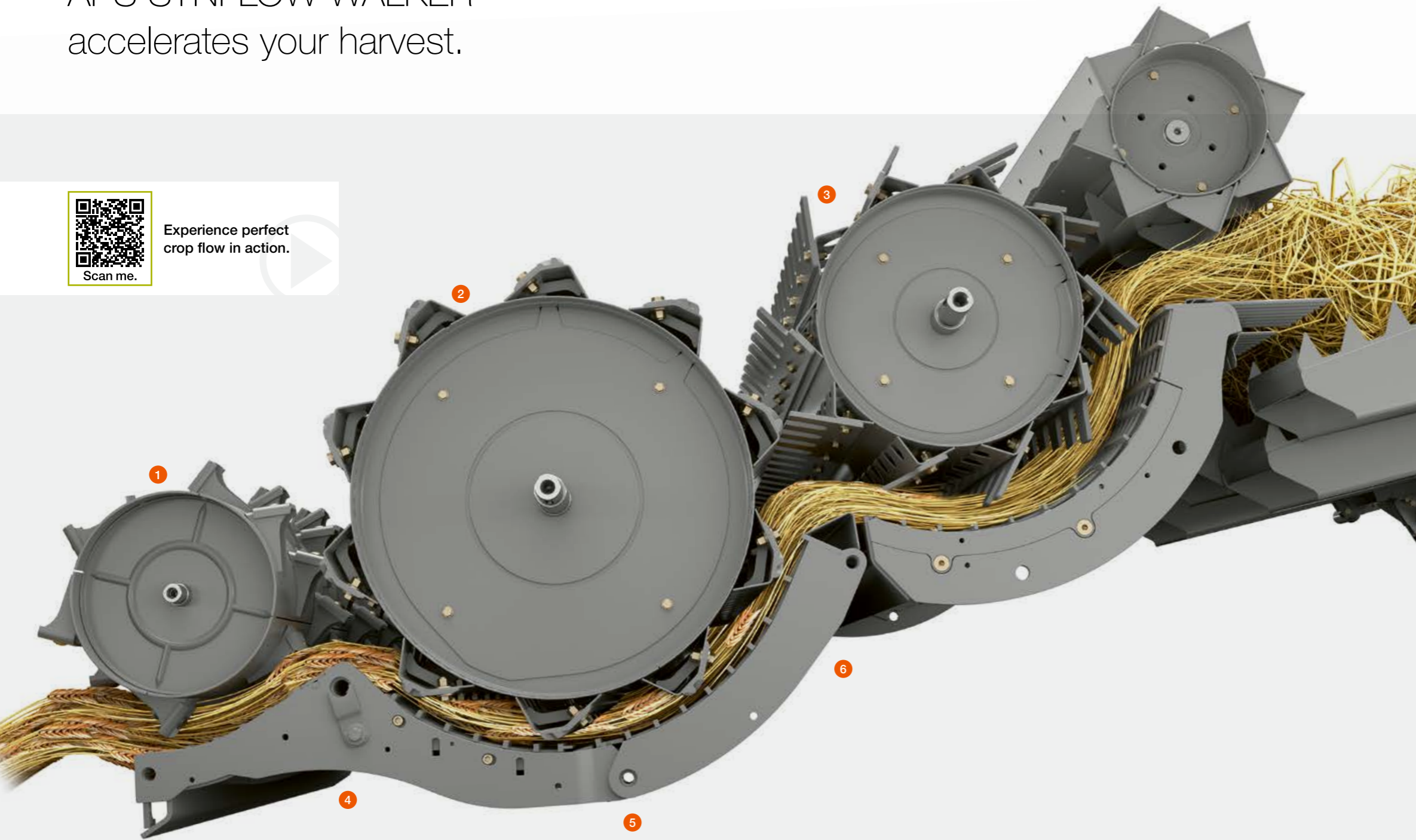

1 Maximum separation performance.

Smooth acceleration of crop flow to as much as 20 m/s under the threshing drum.

2 755 mm threshing drum.

Large threshing drum for high separation performance and stable throughput.

3 600 mm separator drum.

Large separator drum with active separation delivers greater throughput.

4 Pivoting concave bar.

Can be engaged hydraulically via CEBIS for fast adjustment to the threshing conditions.

5 Hydraulic threshing concave flap.

Can be engaged hydraulically from the cab or manually from the outside in the event of a change in harvesting conditions.

6 Synchronised adjustment.

The preconconcave and threshing concave are adjusted in parallel. The drum speed changes are synchronised.

Excellent straw quality.

The APS SYNFLOW WALKER threshing system is gentle on the straw as a result of a particularly straight crop flow. This design means that the crop takes the shortest path through the threshing unit. The large diameter of the threshing and separator drums enables small contact angles and flat transitions between the drums. The outlet of the separator concave is larger than its inlet. The increasing width of the gap prevents the crop from building up and causing congestion. There is hardly any mechanical stress on the straw.

Exceptional throughput.

Numerous adjustment options increase straw quality as well as throughput. These include the parallel, independent adjustment of the threshing and separator concaves, the threshing drum speed reduction gearbox and the pivoting concave bar. The APS system (APS: Accelerated Pre Separation) accelerates the crop flow smoothly to as much as 20 m/s and generates high centrifugal force for maximum separation performance across all concave areas.



APS SYNFLOW threshes every crop.

Increase throughput and straw quality.

The new APS SYNFLOW WALKER threshing system is unique in the straw walker combine harvester segment. It brings together the accelerated crop flow provided by APS with an additional separator drum after the threshing drum. In this way, you can benefit from exceptional throughput rates with excellent straw quality at the same time.

Easy actuation of preconconcave flap and threshing concave flap.

In order to react to a change in crop type or for flexible adjustment of the friction path in the threshing and separation sections, the operator can engage the preconconcave flap and the threshing concave flap manually from outside. The threshing concave flap is also available with optional hydraulic adjustment. When this option is specified, it can be operated conveniently from the cab and is integrated in CEMOS AUTO THRESHING.

Synchronised speed adjustment.

The threshing drum speed can be matched easily to all conditions and crop types. It can be adjusted in CEBIS to any setting between 330 and 930 rpm. The speeds of the accelerator drum, the separator drum and the impeller change in synchronisation.

Perfect adjustment of threshing unit.

In order to align your LEXION optimally with your business and your preferred crops, six threshing unit versions and three rework kits are available to match the profile of the areas you work. The range allows you to find the ideal threshing unit for rice, maize, beans and grains with high or low yields.

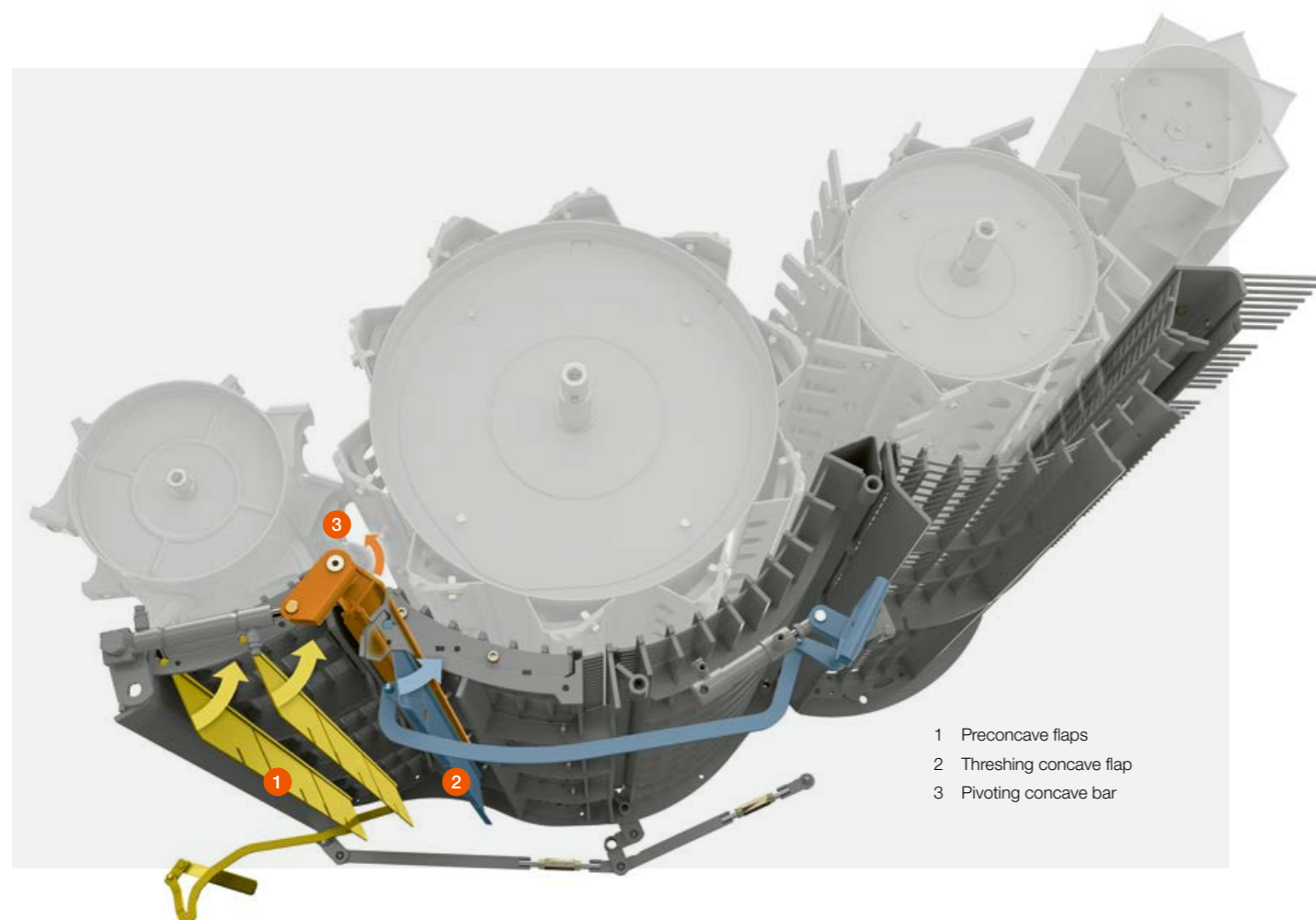

- 1 Preconconcave flaps
- 2 Threshing concave flap
- 3 Pivoting concave bar

Parallel adjustment of threshing concave.

CEBIS allows infinitely variable hydraulic adjustment of the position of the threshing concave. As this involves the parallel and synchronised adjustment of the preconconcave, threshing concave and separator concave, you can be certain that the entire crop flow will run evenly while handling the straw gently. Integrated overload protection prevents blockages and protects the threshing unit from damage.

Hydraulically pivoting threshing concave bar.

For clean threshing under all conditions, including when deawning or decortication is difficult, the threshing concave bar can be pivoted hydraulically via CEBIS. Like the hydraulic actuation of the threshing concave flap, this comfort feature is integrated in CEMOS AUTO THRESHING.

Change concave segments quickly.

Changeover times from one crop type to another are getting ever shorter. When a changeover is carried out, the main components of the threshing concave remain in the machine. You can quickly change the preconconcave segments through the stone trap simply by pulling the threshing concave segment out to the side. The numerous combination options are the key to the unique MULTICROP capability of the LEXION.



A LEXION makes the most of your crop.

- 1 Separator drum
- 2 Pre-separation concave
- 3 Returns pan
- 4 Open straw walkers

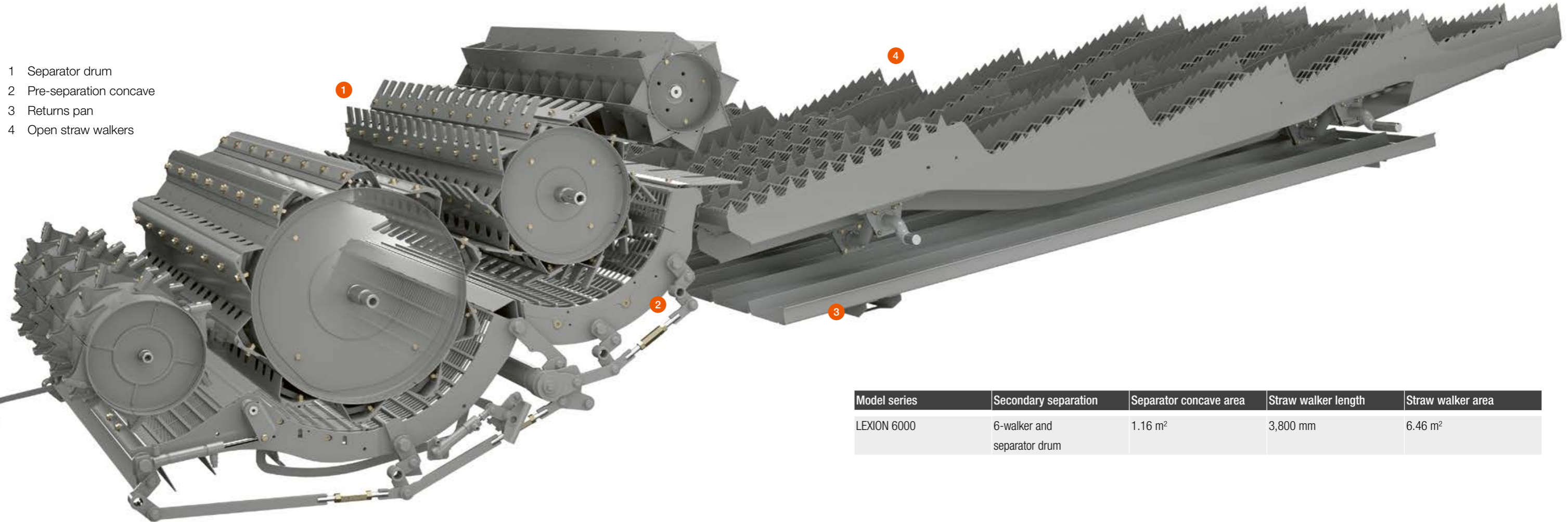

Model series	Secondary separation	Separator concave area	Straw walker length	Straw walker area
LEXION 6000	6-walker and separator drum	1.16 m ²	3,800 mm	6.46 m ²

Every grain counts.

The even flow of the straw onto the open-bottomed straw walkers combined with an extreme gradient angle ensures that practically all the residual grain is separated from the straw. This process is unaffected by the difficulty of the harvesting conditions or whether you are threshing wet or dry straw.

The mixture of grain, straw and chaff first reaches the preparation floor via the separate returns pan before passing over the straw walker steps to the sieve pan. This significantly reduces the load on the sieve pan.

Every grain counts in the harvest.

- Thanks to the APS threshing system, only some 10% of grains go through the residual grain separation system.
- Even large volumes of straw are transported quickly and easily by the six straw walkers.
- No grains are lost, even under difficult field conditions (wet straw, green growth).

Separator drum.

Synchronised with the other drums, a separator drum with a diameter of 600 mm gets every last grain out of the straw.

- High-performance separation with top-quality straw
- Low mechanical load on the straw as a result of the limited contact angle

Large straw walker area.

The secondary separation via the straw walkers is accomplished over a total length of 3,800 mm across four straw walker steps. Even large volumes of straw are transported rapidly and loosely.

- Large separation area for precise secondary separation
- Centre and side risers to fluff material
- Maintenance-free, robust straw walker bearings



Clean grain is worth real money.

Intensive cleaning.

Clean grain is worth real money. The JET STREAM cleaning system with its hydraulic fan speed variator and high-performance returns has plenty of performance capacity in reserve in all crop types. A dual-ventilated step enables intensive pre-cleaning.

JET STREAM is controlled conveniently from the cab. You no longer have to adjust anything manually. As an option, you can put the JET STREAM cleaning function under the fully automatic control of CEMOS AUTO CLEANING.



The best way to the best grain.

- The JET STREAM cleans the grain intensively.
- The 3D cleaning system keeps the cleaning performance stable when operating on slopes.
- CLAAS PREMIUM LINE parts provide a longer service life.

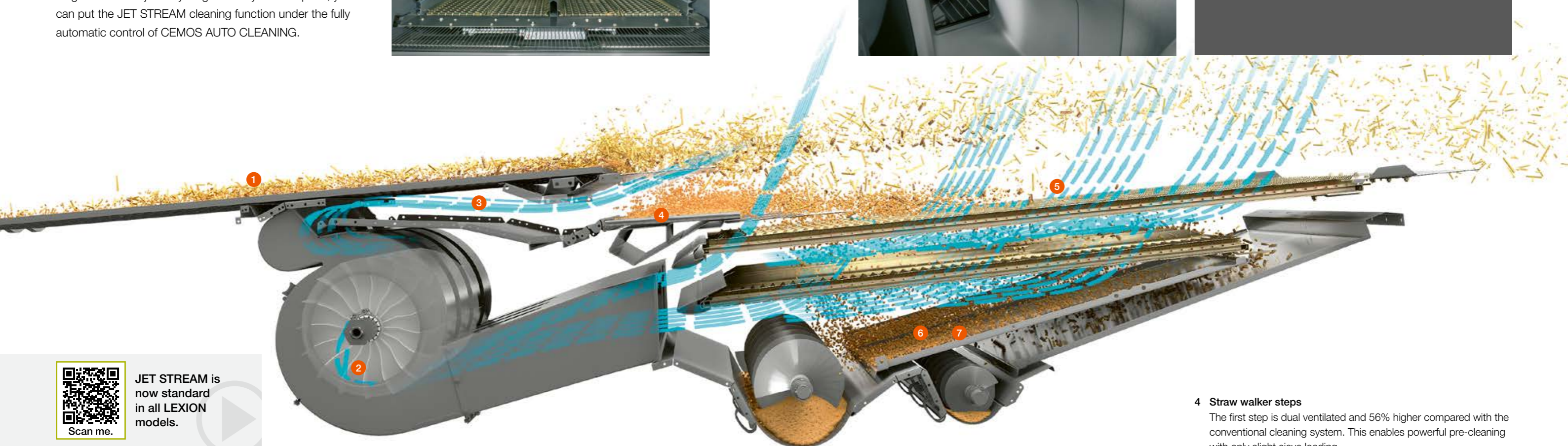

JET STREAM is
now standard
in all LEXION
models.

Scan me.

4 Straw walker steps

The first step is dual ventilated and 56% higher compared with the conventional cleaning system. This enables powerful pre-cleaning with only slight sieve loading.

5 3D cleaning system

The maintenance-free system operates in the background. Using active transverse control, it distributes the material evenly across the upper sieve. This ensures that the cleaning performance remains stable when operating on slopes.

6 GRAINMETER

The GRAINMETER analyses the returns using a light barrier. This makes it possible to calculate the proportion of grains to the total volume. These data are also used by CEMOS AUTOMATIC.

7 Returns

The returns recovers every last grain from unthreshed ear sections. The material is deposited on the accelerator drum, spread out and fed to the threshing drum again.

1 Preparation floor

This increases the cleaning capacity of the LEXION while also reducing the load on the upper sieve. The plastic preparation floor elements can be removed through the stone trap for easy cleaning.

2 Turbine fan

The powerful turbine fan has sufficient reserves for difficult conditions. The hydraulic variator can be controlled by CEMOS AUTO CLEANING.

3 Airflow equalisation duct

The long airflow equalisation duct with the airflow oriented upwards provides consistent cleaning performance and already achieves a high degree of separation at the first step.



Collect your grain quickly and reliably.

Up to 13,500 l of grain in the tank.

With a volume of up to 13,500 litres, the grain tank has a capacity to match the increased throughput of the LEXION. Buttons on the armrest control the automatic opening and closing of the grain tank. Additional steps and handrails make access even safer.



Grain tank unloading at up to 180 l/s.

At 180 l/s you can unload the large grain tank of the LEXION in record time. The rate can be reduced from 180 l/s to 90 l/s. If necessary, you can stop the process immediately or turn off the augers gradually in order to completely empty the grain tank unloading tube first.

- Reliable filling of the transport vehicles
- No losses during unloading

Precise yield measurement.

The QUANTIMETER determines the yield quickly and precisely by means of a baffle plate with an integrated measuring cell at the ejection point of the grain elevator. This system can be calibrated from the cab.



- 1 Grain elevator
- 2 GRAIN QUALITY CAMERA
- 3 QUANTIMETER yield measurement
- 4 Moisture measurement

Greater height and reach for easy unloading.

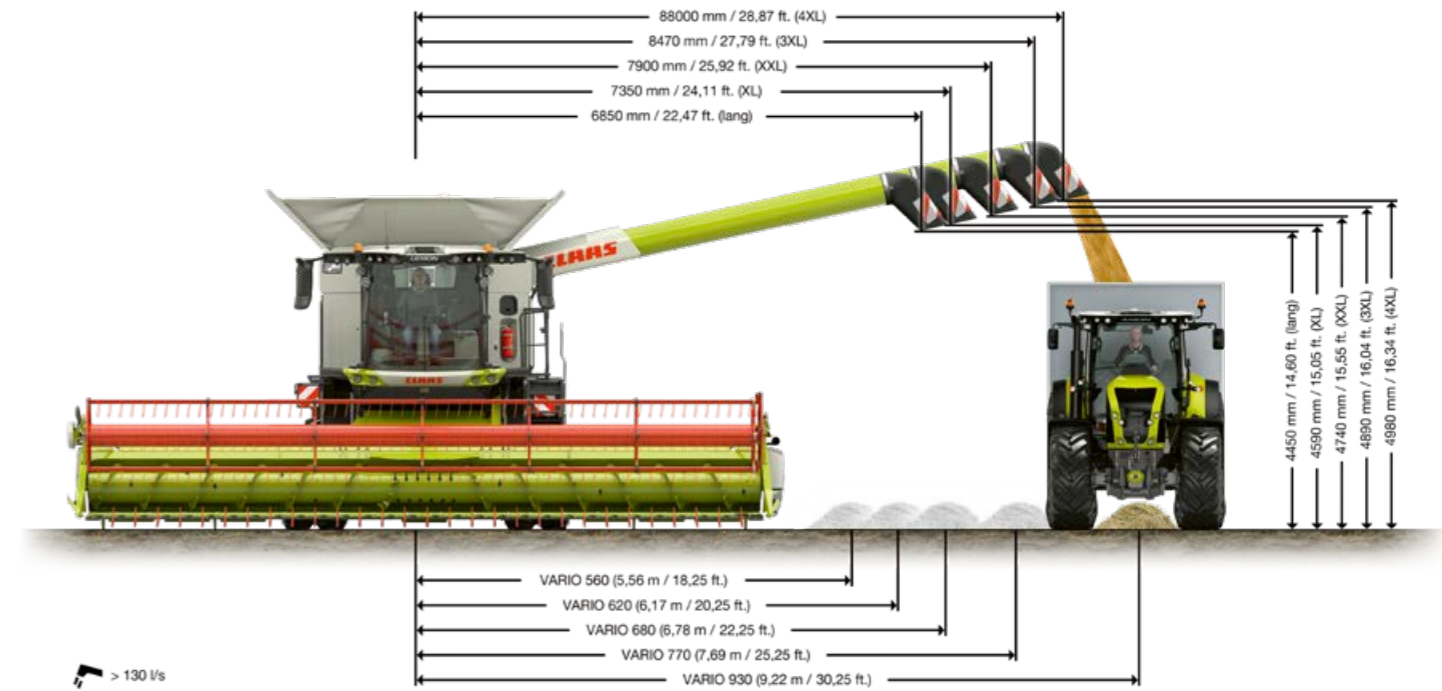

NEW: Grain tank unloading tube with pivoting spout.

The pivot angle of 105° allows you an excellent view of the grain tank unloading tube. You can select the length of the tube in accordance with the width of the front attachment. The diameter depends on the desired unloading rate: 420 mm for 180 l/s or 330 mm for 80 to 130 l/s.

The stream of material is concentrated by a pivoting spout at the end of the tube. This can be adjusted via the CMOTION multifunction lever and makes it easier to load the transfer vehicles precisely.

Reliable collection.

The concentrated stream makes reliable filling of trailers easier. The automatic cover flap at the end of the grain tank unloading tube ensures that there are no run-on losses during the unloading process.

Precise GRAIN QUALITY CAMERA.

The GRAIN QUALITY CAMERA provides real-time pictures of the crop. As the software identifies non-grain constituents and broken grains, you can use CEBIS to monitor the grain quality and assess it digitally at any time.

NEW: 4XL and 5XL folding grain tank unloading tubes.

The folding variants of the grain tank unloading tube reduce the overall length of the machine. This means that the LEXION takes up less space on the road and in the machine shed.



Its straw management is excellent.

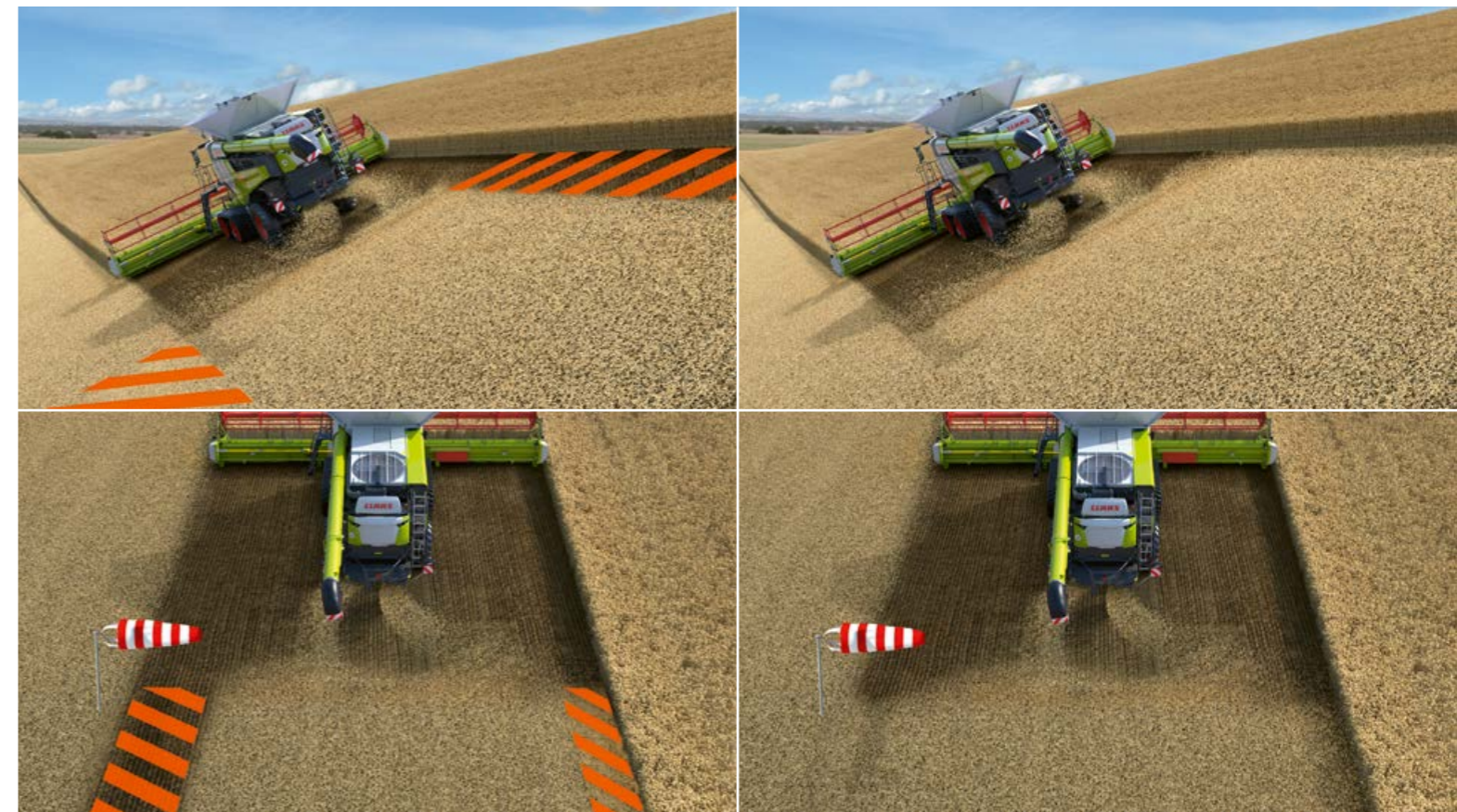

The following crop starts here.

High straw volumes, changing levels of straw moisture, side slopes and large working widths are particular challenges during grain harvesting. Excellent straw and chaff spreading performance is one of the hallmarks of the LEXION. High-quality chopping and precise spreading of the chopped straw provide a sound basis for subsequent tillage and cultivation.

Top performance with all crops.

In addition to two straw chopper drives with a manually adjustable chopper speed, there is also a version with hydraulic speed adjustment which can be controlled conveniently from the operator's seat. This option comes into its own when you have to work frequently in changing crop types. During swathing, a neutral setting saves fuel and reduces wear.

Precise straw spreading.

Even when the machine is operating in strong crosswinds, handling high straw volumes or negotiating side slopes, the power spreader always deposits the straw precisely. Comprising two discharge rotors turning in opposite directions at a constant speed, it takes both the chopped material and the chaff straight from the cleaning section, accelerates it further and spreads it evenly across the entire working width.

Automatic discharge direction adjustment.

You can equip your LEXION with two sensors which automatically adjust the discharge direction of the chopped material to the terrain conditions. The sensors are fitted on the light brackets at the rear of the machine and ensure that the power spreader and deflector spread the chopped material evenly on slopes or in the event of crosswind. You set the sensitivity of this system in CEBIS.

Targeted chaff spreading.

During swathing, the chaff blower automatically turns outwards. Swaths of long straw and chaff/broken straw mixture are laid separately. For straw spreading, however, the chaff blower forces the sieve pan discharge straight into the power spreader for active distribution. The chopped straw and the sieve pan discharge are spread across the entire working width.

Technology that makes your straw management efficient:

- Power spreader for precise straw deposition when operating in strong crosswinds, handling high straw volumes or negotiating side slopes
- Switchover to swathing from the cab
- CEMOS AUTO CHOPPING for optimal chopped material quality and lower fuel consumption



Sensor for automatic discharge direction adjustment.



Static knife and pivoting bottom element in the SPECIAL CUT chopper.

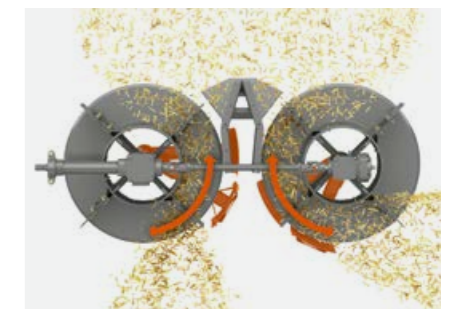

Power spreader for efficient straw spreading with minimal use of power.

Campaign performance needs power. CLAAS Power Systems.

Interplay of optimal components.

Top performance happens when all the parts of your CLAAS machine are precisely matched to each other and work together optimally. CLAAS POWER SYSTEMS brings together the best components to form an intelligent drive system: drives which are suited to your requirements and the way you use your machines; full engine output only when you require it; fuel-saving technology which quickly pays off.

Don't accept any compromises.

You have many possibilities for optimising the LEXION to meet the characteristics of your farm and your fields so precisely that your campaign performance increases to a significant degree.

- The LEXION 6800 top-of-the-range model is equipped with a Perkins six-cylinder engine with 461 hp and a displacement of 12.5 l.
- DYNAMIC POWER adjusts the engine output to the power requirement. This allows you to achieve fuel savings of up to 10%.
- DYNAMIC COOLING reduces your diesel costs. The variable fan drive adjusts its speed automatically in line with the degree of cooling required.
- TERRA TRAC reduces soil compaction. The crawler track units offer a high level of driving comfort and are narrow enough for road travel.
- For greater tractive power in difficult terrain you can equip your machine with a POWER TRAC all-wheel drive.
- The differential lock ensures high traction and pulling power on slopes and in the wet.



DYNAMIC POWER – the intelligent way to put power down.

More intelligence for the engine.

DYNAMIC POWER automatically adjusts the engine output of your LEXION to the operating conditions. This means that you are always running with the most efficient power curve when operating under partial load and can save – during swathing, for example – up to 10% of fuel. At full load when the grain tank is being unloaded and the straw chopper is engaged, for example, maximum engine output is automatically maintained.

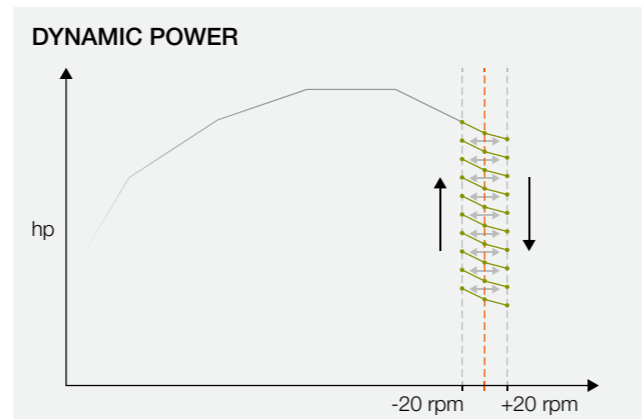

Intelligent power.

DYNAMIC POWER uses a variety of power curves on the basis of the engine load. The parameter which triggers the power adjustment is the reduction or increase in the engine speed resulting from a change in the power requirement.



Perkins 2206 D

LEXION		6800	6800 TT	6700	6700 TT
Model		Perkins 2206 D	Perkins 2206 D	Perkins 2206 D	Perkins 2206 D
Cylinders / displacement	No./l	6/12.5	6/12.5	6/12.5	6/12.5
Maximum output	kW/hp	339/461	339/461	308/419	308/419



Lower revs on the road.

On the road, the LEXION makes do with just 1,600 rpm. This technology makes it possible for you to save significantly more fuel while running at a reduced noise level and with a high level of driving comfort.



Technology that helps you save fuel:

- The LEXION 6800 is equipped with a Perkins six-cylinder engine with 461 hp and a displacement of 12.5 l.
- DYNAMIC POWER adjusts the engine output to the current power requirement.
- You are always operating with the most efficient performance curve in the partial load range.
- Fuel savings of up to 10% are possible during swathing.
- The engine speed is reduced to 1,600 rpm during road travel.
- This significantly reduces the noise level and diesel consumption.

DYNAMIC COOLING – the smart solution.



DYNAMIC COOLING in every LEXION.

Based on a variable fan drive which is unique in the combine harvester sector, DYNAMIC COOLING adjusts its speed automatically and, above all, in accordance with the degree of cooling required. Whatever the outside temperature, DYNAMIC COOLING is able to cope easily. The system not only delivers reliable cooling, but also uses a curtain-effect air flow to reduce the extent to which dust is able to rise. DYNAMIC COOLING requires 20 kW less engine output, thereby helping you to save fuel.

What makes DYNAMIC COOLING so unique?

- Variable fan drive provides cooling when required
- Provides effective and reliable cooling
- Uses full fan speed only under full load
- Minimises extent to which dust is able to rise
- Reduces soiling of the radiator and engine compartment
- With grain tank unloading tube extended, automatically increases speed to actively blow dust away from engine compartment
- Extends the air filter maintenance intervals

Cooling and cleaning in one.

Drawn in vertically at the top, the fresh air passes through a rotating sieve with a diameter of 1.60 m. It is then vented through the engine compartment and over side cooling fins. This ideal air flow prevents almost all dust from rising and so effectively functions as a permanent cleaning system.

Large cooling package for sufficient reserves of cooling capacity.

- 1 Radiator
- 2 Oil cooler
- 3 Intercooler
- 4 Condenser
- 5 Fuel cooler



Your time is too valuable to waste.

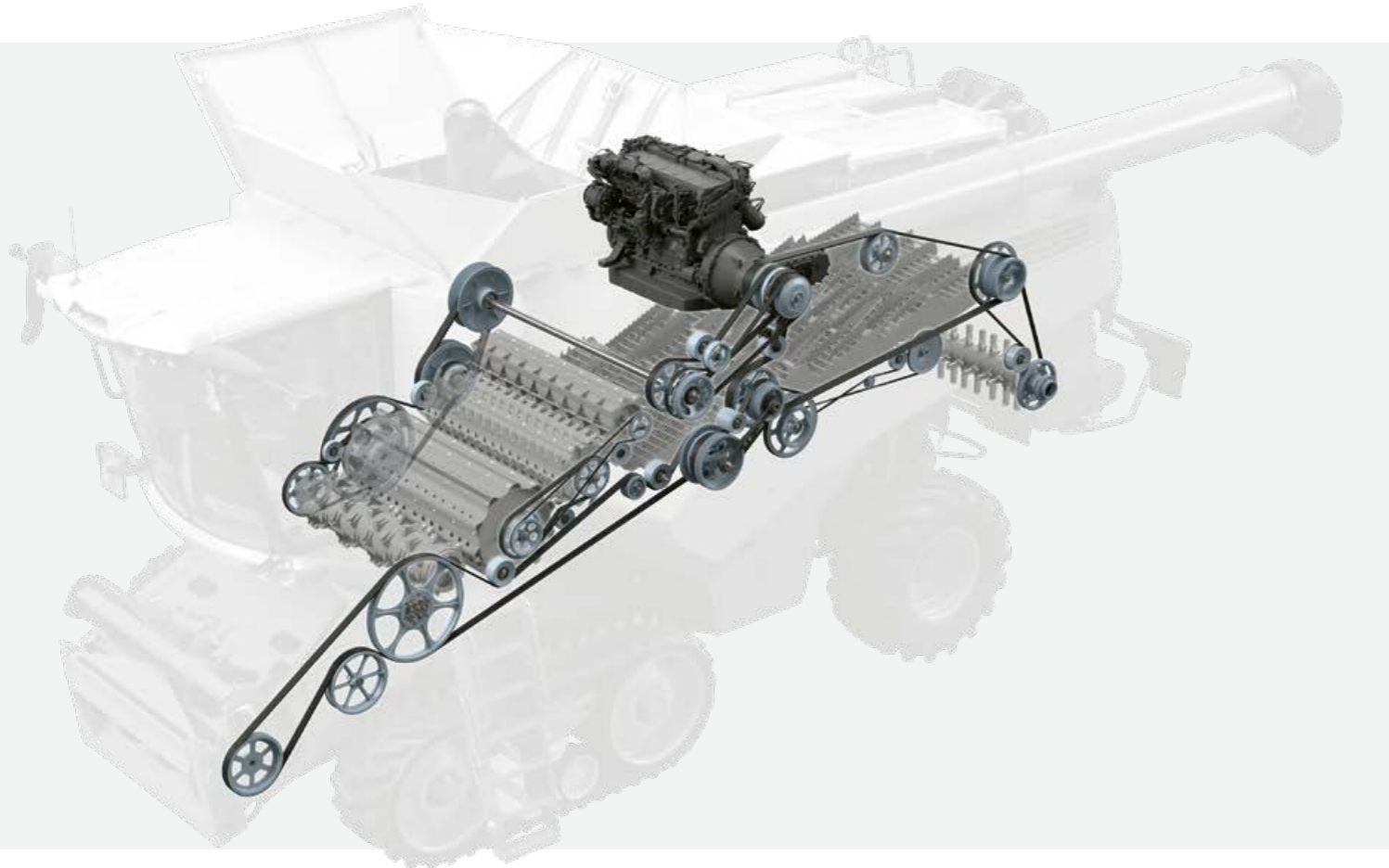

Hydrostatic ground drive up to 40 km/h.

All LEXION models are equipped with a 2-speed hydrostatic ground drive with convenient gear selection via the buttons on the armrest. The high efficiency of the hydrostatic motor saves power which is available to the rest of the machine. Both the wheeled machines and the TERRA TRAC models can travel at up to 40 km/h.

Automatic parking brake for your safety.

If you run for more than one second at less than 1 km/h, change gear, switch the engine off or get out of the seat, the LEXION automatically activates the parking brake. This increases both driving comfort when making frequent stops and your safety when you leave the cab. The brake is released again as soon as you operate the ground speed control lever.



40 40 km/h top speed for all wheeled machines and TERRA TRAC models.

A drive system that has what it takes:

- Hydraulically actuated dry clutch
- Hydraulically tensioned main belts
- Standardised belt tensioners
- Improved power transmission
- Lower maintenance costs



Differential lock for improved traction.

The electrohydraulically operated differential lock, which is activated simply by means of a pushbutton in the centre console, ensures that you can continue to operate safely and reliably in extreme conditions. The high traction and pulling power of the LEXION are maintained on slopes and in the wet. You can also engage the differential lock under load.

Tyres for high level of soil protection.

Tyre diameters of up to 2.15 m for the front wheels and 1.65 m for the rear help you protect the soil while working.

Automatic function for more comfort.

The differential lock automatic engagement and disengagement function makes working with the LEXION particularly comfortable and safe.

- Automatic engagement when ground speed is less than 10 km/h, steering angle less than 15° or slip occurs
- Automatic disengagement when ground speed is over 10 km/h, steering angle over 15° or braking occurs

Powerful POWER TRAC all-wheel drive.

When ground conditions are difficult, a push of a button is all it takes to engage the all-wheel drive in order to benefit from greater traction. Or you can use the standby mode, in which the all-wheel drive is permanently available in the background and can be activated quickly if required.

- ON: rear wheels are mechanically engaged and are driven
- STANDBY: rear wheels are mechanically engaged but are not driven
- OFF: rear wheels are mechanically disengaged



The soil is your greatest asset.

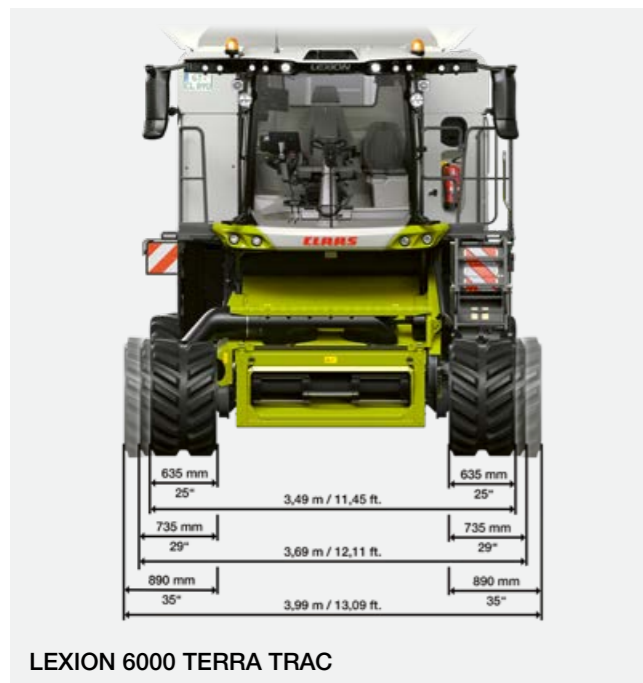

LEXION 6000 TERRA TRAC

TERRA TRAC for every requirement.



TERRA TRAC 635 mm



TERRA TRAC 735 mm



TERRA TRAC 890 mm



TERRA TRAC 890 mm
spoke design



TERRA TRAC 890 mm rice

Third-generation crawler unit.

The soil is the most important basis for production available to you. As it is impossible to create more of it, you need to be able to obtain ever greater yields from the existing land. The key to this is more productive machines which, thanks to TERRA TRAC, are extremely gentle on the soil.

The third generation of TERRA TRAC crawler tracks impresses with the large diameter of the land wheels, hydropneumatic suspension, improved track tensioning and automatic level compensation from 2 km/h. The TERRA TRAC system increases traction drastically and leaves hardly any trail behind it when operating in the wet, on soft ground or on side slopes. This makes the work of the transport vehicles considerably easier.

TERRA TRAC on the road.

- 40 km/h top speed possible
- Fully suited to road travel at 20, 25, 30 and 40 km/h
- High driving safety and directional stability
- More driving comfort compared with a wheeled machine

TERRA TRAC in the field.

- Up to 66% less ground pressure than wheeled machines
- Better traction in maize, in the wet and on slopes
- Less slip and greater stability on side slopes
- Lower drive resistance and fuel consumption

TERRA TRAC in rice.

- Special rice track, 890 mm wide
- Greater spacing of tread lugs for self-cleaning
- High traction and load-bearing capacity
- Will not sink in when operating in wet field conditions

A comfortable working environment also helps to increase productivity.

Working days are getting longer.

Achieving high campaign performance means being aboard your machine from morning to evening. It is therefore clear that you need all the support you can get. This is another area in which the LEXION has more to offer than ever before: from self-learning operator assistance systems to high end lighting packages that keep the area which you are working as bright as day.

Comfort improves performance.

We know that you work better in the field when you have a comfortable working environment. This is why the cab of the LEXION is designed for comfort. As well as being distinctly spacious at head, shoulder and leg level, it features an intelligent control concept and a bright CEBIS terminal which provides a razor-sharp display of all the information you need.

- Whether the day is hot or cold, you will be in your comfort zone. The optimised airflow ensures a pleasant temperature in the cab.
- You will also be comfortable throughout the longest of working days, whether you choose the standard seat or the premium leather seat.
- Everything is safely stowed and kept pleasantly cool in the storage compartments in the B-pillar or the cool box under the instructor's seat.
- Stay informed and well organised with the digital radio with hands-free facility and the tablet holder.
- You can keep working when night falls thanks to the LED work lights and the maintenance lighting available in a number of different versions and configurations.
- Camera systems give you a clear view for added safety and convenience when performing tasks such as unloading the grain tank or hitching up the cutterbar trailer.



When we want to improve something,
we ask you first.



Everything the way you want it.

When we are refining one of our combine harvester models, we always include the cab concept in our design considerations. We are supported in this by combine harvester operators all over the world. Together with them, we take the important decisions relating to the comfort and control aspects of our machines. Proven approaches are continued, good solutions are improved, new ideas are put to the test.

We are certain that you will welcome the new cab of the LEXION, especially the air conditioning concept with its more efficient airflow, the extra space at head and leg level, the actively cooled 30 l cool box for your drinks or the bright, high-resolution CEBIS display. Of course the fundamentals remain unchanged: the incomparable CLAAS comfort, for example, or the intelligent control concept which gives you easy access to all machine functions.



1 Bright CEBIS terminal

The razor-sharp HD display tells you what you need to know at a glance.

2 Intuitive CEMIS 1200 terminal

CEMIS 1200 provides support for precision GPS tracking and networked documentation.

3 Armrest with direct adjustment

Your right hand intuitively operates all the important machine functions.

4 More legroom

Comfort is enhanced by the spacious legroom and the wide foot rests.

5 Comfortable seats

The operator's seat with a 30° swivel angle (optional) and a comfortable instructor's seat look after your back, even on long working days.

6 Good all-round view

Cantilever mirror arms allow a clear view to all sides.

7 Spacious storage compartments

Everything you need to take with you is safely accommodated in the LEXION.

8 Large grain tank inspection window

For even easier crop monitoring.

9 High-end lighting package

Benefit from 360° illumination of your working area (optional).

10 Bright LED front area lighting

Up to 26 work lights flood the entire working area in light as bright as day.

11 Subdued cab lighting

The interior of the cab is pleasantly illuminated, LED light strips illuminate the storage compartments.

12 Air conditioning

Work at a comfortable temperature, whether the day is cold or hot.

LED lighting packages
turn night into day.

- The long-range work light provides illumination over a particularly long distance.
- The front attachment is illuminated as brightly as the front area, sides and stubble.
- All the important machine components are equipped with maintenance lighting.

A LEXION is easy to drive.

CEBIS operates intuitively.

Operation is intuitive and possible without previous knowledge. This means that even new operators are able to use the LEXION in a short time. CEBIS plays a decisive role in this. The system is an information supplier, performance optimiser and problem solver all rolled into one.

CEBIS offers immediate assistance.

Stored in CEBIS is a library of measures – based on the experience of countless CLAAS combine harvester operators – for resolving various problem scenarios. They consider all the parameters which could contribute to solving the problem. They therefore represent a comprehensive resource which supports you in making full use of the installed capacity of the machine.

CEBIS simplifies the menu.

Beginner, normal or expert: you define your user type and CEBIS adjusts the menu system to your level of experience. This ensures that new operators are not overwhelmed by complex menus. The operator assistance system is also integrated in CEBIS. You operate CEMOS DIALOG and CEMOS AUTOMATIC via the user-friendly touchscreen. Using a slider, you program the system's automatic functions with the strategies you wish them to follow.



CEMOS DIALOG integrated in CEBIS.



Intelligent control by CEMOS AUTOMATIC via CEBIS.

1 CEBIS touchscreen

CEBIS responds immediately to a tap on the touchscreen. You have direct access to the field work and road travel machine functions as well as to all the operator assistance modules, such as CEMOS AUTOMATIC.

2 CEBIS rotary push switch

Even when operating in bumpy terrain in the field, you can easily navigate the CEBIS control panel using rotary/push switches and the Escape and Favourites buttons – to adjust the threshing drum speed, for example.

3 Direct adjustment via switches

You operate predefined basic functions directly by means of assigned switches. In this way, you can adjust the sieve opening or the fan speed, for example.

4 CMOTION favourites management

Seven settings can be programmed as favourites in CEBIS. When working, you can call these up conveniently via rocker switches on the CMOTION ground speed control lever. Your hand intuitively actuates the relevant switches while you keep a close eye on the front attachment.

User-friendly design that supports the operator and reduces stress.

- Depending on your preference, settings can be adjusted in three ways in the LEXION: via the CEBIS touchscreen, the CEBIS rotary push switch or the direct-adjustment switches.
- Operating the direct adjustment system causes a dialogue box to open in CEBIS.
- A numeric keypad helps you enter precise target values.
- All parameters can be modified easily by means of dial and slide controllers in CEBIS.
- All the functions of the CEMOS AUTOMATIC operator assistance system, as well as CEMOS DIALOG, are integrated in CEBIS.
- You can call up your seven favourites directly on the CMOTION ground speed control lever.

Every harvest benefits from these systems.

Digitalisation is indispensable.

There are very good reasons for the digitalisation of our machines – three to be precise: we want to help your operators work more confidently, to make your harvest go more smoothly and to reduce your costs. With self-learning operator assistance systems such as CEMOS AUTOMATIC, for example, or steering systems that are accurate down to the last centimetre.

Connected machines are more productive.

To enable you to get more out of your CLAAS machines, we have a range of modules to connect them with the farm. The line-up extends from yield mapping to fleet coordination to continuous documentation of your job and yield data.

- Let CEMOS AUTOMATIC reduce your workload significantly. Select the appropriate modules from entry level to the full version.
- CEMOS AUTO HEADER actively controls the position of the reel and the VARIO cutterbar table.
- The more precise your movements in the field, the more efficiently you will be able to harvest. Accurate down to as little as 2.5 cm, LASER PILOT and GPS PILOT CEMIS 1200 keep the number of passes required to a minimum.
- Collect and process your data how and where it suits you. TELEMATICS, automatic documentation, CLAAS API and DataConnect give you a whole host of options.
- Increase throughput, grain quality and comfort. Active forward travel control or a threshing unit which adjusts itself help you achieve these goals.
- CEMOS CONNECT ensures that all the combine harvesters in a fleet operate with the same efficient settings.



CEMOS operators are unbeatable.

Configure CEMOS AUTOMATIC for your specific requirements.

CEMOS AUTOMATIC is a self-learning operator assistance system which provides you and your operators with continuous, active support throughout the entire work process. On the basis of harvesting parameters, such as grain quality, threshing quality, standard of cleaning, straw quality and throughput, the system checks sensors and settings. It optimises your LEXION to its technical performance limits while it is running.

The operator decides.

You tell the system your requirements concerning the grain quality and loss level. During harvesting, CEMOS AUTOMATIC optimises the performance of your machine to meet your criteria precisely.

Assemble your own CEMOS solution.

Whether you choose the entry level or full version, you configure your very own CEMOS AUTOMATIC system on the basis of the functions that will make sense in your fields and optimise your work.

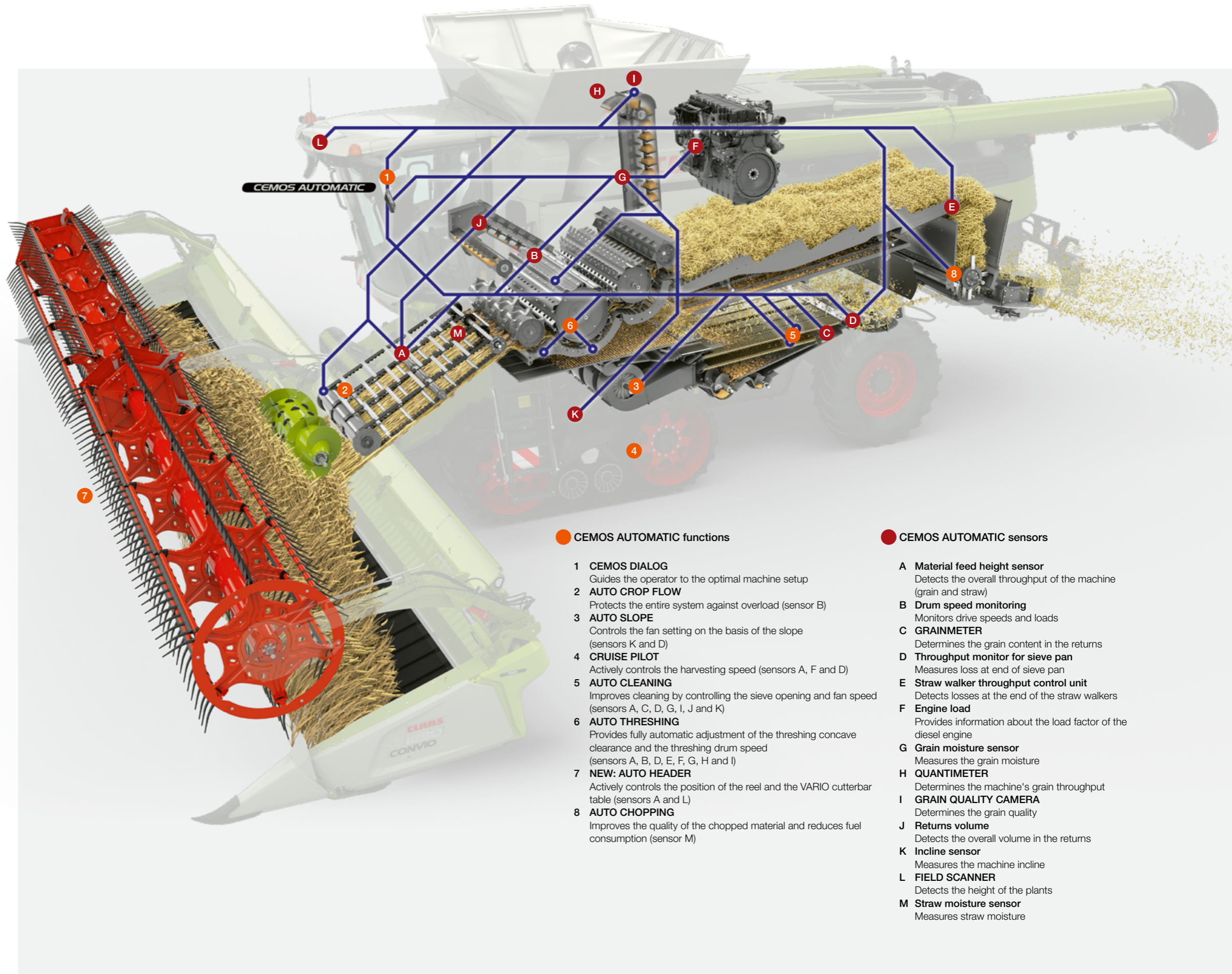

● CEMOS AUTOMATIC functions

- 1 CEMOS DIALOG**
Guides the operator to the optimal machine setup
- 2 AUTO CROP FLOW**
Protects the entire system against overload (sensor B)
- 3 AUTO SLOPE**
Controls the fan setting on the basis of the slope (sensors K and D)
- 4 CRUISE PILOT**
Actively controls the harvesting speed (sensors A, F and D)
- 5 AUTO CLEANING**
Improves cleaning by controlling the sieve opening and fan speed (sensors A, C, D, G, I, J and K)
- 6 AUTO THRESHING**
Provides fully automatic adjustment of the threshing concave clearance and the threshing drum speed (sensors A, B, D, E, F, G, H and I)
- 7 NEW: AUTO HEADER**
Actively controls the position of the reel and the VARIO cutterbar table (sensors A and L)
- 8 AUTO CHOPPING**
Improves the quality of the chopped material and reduces fuel consumption (sensor M)

● CEMOS AUTOMATIC sensors

- A Material feed height sensor**
Detects the overall throughput of the machine (grain and straw)
- B Drum speed monitoring**
Monitors drive speeds and loads
- C GRAINMETER**
Determines the grain content in the returns
- D Throughput monitor for sieve pan**
Measures loss at end of sieve pan
- E Straw walker throughput control unit**
Detects losses at the end of the straw walkers
- F Engine load**
Provides information about the load factor of the diesel engine
- G Grain moisture sensor**
Measures the grain moisture
- H QUANTIMETER**
Determines the machine's grain throughput
- I GRAIN QUALITY CAMERA**
Determines the grain quality
- J Returns volume**
Detects the overall volume in the returns
- K Incline sensor**
Measures the machine incline
- L FIELD SCANNER**
Detects the height of the plants
- M Straw moisture sensor**
Measures straw moisture

Optimise CEMOS AUTOMATIC for your harvest.

The functions of CEMOS AUTOMATIC.

In CEMOS AUTOMATIC you have a self-learning, modular operator assistance system. Choose from the set of available functions the ones that are most cost-effective for your farm.

CRUISE PILOT and AUTO SLOPE, for example, provide economical access to automation. With these functions, as well as benefiting from intelligent forward travel control, your LEXION is able to adjust the fan speed automatically. This allows the grain cleaning system to operate without losses in undulating terrain.

Or you can choose the full version of CEMOS AUTOMATIC and let the machine optimise its threshing unit, primary and secondary separation autonomously. You benefit from high throughput, clean grain and reduced fuel consumption.

Harvesting at the limit.

- Your operators' workload is reduced significantly.
- They achieve more throughput and a high standard of grain cleaning.
- Downtime due to blockages or overloading is avoided.
- The fuel efficiency of your LEXION is improved.
- You have no outages because of incorrect settings.
- You reduce costs and effort effectively.
- You increase your campaign performance.

CEMOS AUTOMATIC secures your campaign performance.

AUTO HEADER
AUTO CHOPPING
AUTO THRESHING
AUTO CLEANING

CRUISE PILOT

AUTO CROP FLOW

CEMOS DIALOG

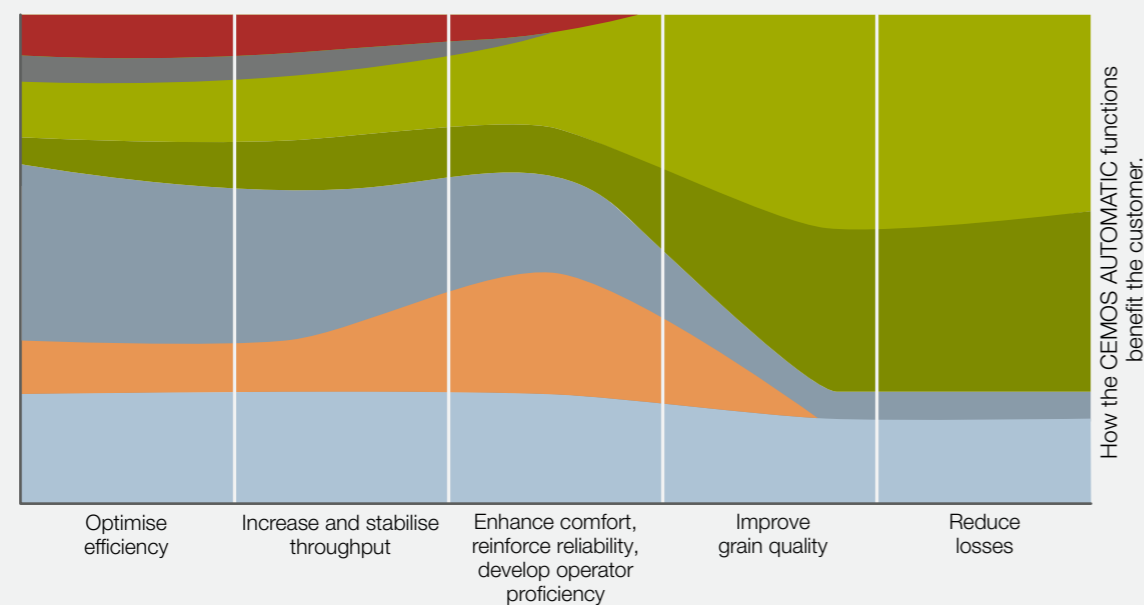

How the CEMOS AUTOMATIC functions benefit the customer.

The CEMOS AUTOMATIC functions support you throughout the entire harvest. You can configure the functions in such a way that they are a precise fit for your requirements. The user-friendly CRUISE PILOT, for example, helps you optimise efficiency while increasing throughput and stabilising it. If you wish to improve the grain quality and reduce losses, AUTO THRESHING will provide you with optimal support.

AUTO CROP FLOW recognises peak loads.

If the preset slip limit is overshoot, AUTO CROP FLOW prevents any more material from entering the machine. This avoids downtime due to blockages, damage or overloading.

AUTO SLOPE manages cleaning on slopes.

AUTO SLOPE reduces your workload by controlling the fan speed on the basis of the longitudinal tilt.

- You increase throughput and reduce grain losses on slopes.
- The cleaning performance always remains stable.
- The crop flow in the cleaning system is maintained.

CRUISE PILOT controls the speed.

The optimal harvesting speed increases your productivity. CRUISE PILOT controls it automatically on the basis of the engine load. It is possible to choose from three strategies:

- 1 Maximum throughput with loss monitoring: you are always harvesting at the machine's performance limit.
- 2 Constant throughput: all the key assemblies are subject to consistent loading even under changing conditions.
- 3 Cruise control: you work at a constant harvesting speed.

CEMOS AUTO CHOPPING.

The positions of the static knife and the friction concave plate are automatically adjusted to the current condition of the straw in order to improve the quality of the chopped material.

CEMOS AUTO CLEANING.

The fan speed and the upper and lower sieve opening are the parameters by which CEMOS AUTO CLEANING automatically regulates the cleaning. In the background, the system continuously tests various settings to optimise performance. If parameters such as yield, grain quality, throughput or moisture change, CEMOS AUTO CLEANING reacts immediately.

CEMOS AUTO THRESHING.

The system improves the performance of the threshing unit and primary separation. It controls the threshing concave clearance and the threshing drum speed fully automatically. A comparison of all the possible settings to optimise performance takes place in the background. The data on which this is based are supplied by numerous sensors in the machine.

NEW: CEMOS AUTO HEADER.

The FIELD SCANNER sensor detects the height of the plants while the material feed height sensor in the feeder housing evaluates the crop flow. On the basis of these data, CEMOS AUTO HEADER actively controls the position of the reel and the VARIO cutterbar table. This results in an optimal crop feed at all times along with a significant reduction in the workload for the operator.



CEMOS AUTO HEADER has been awarded a silver medal by the Agritechnica Innovations Commission.

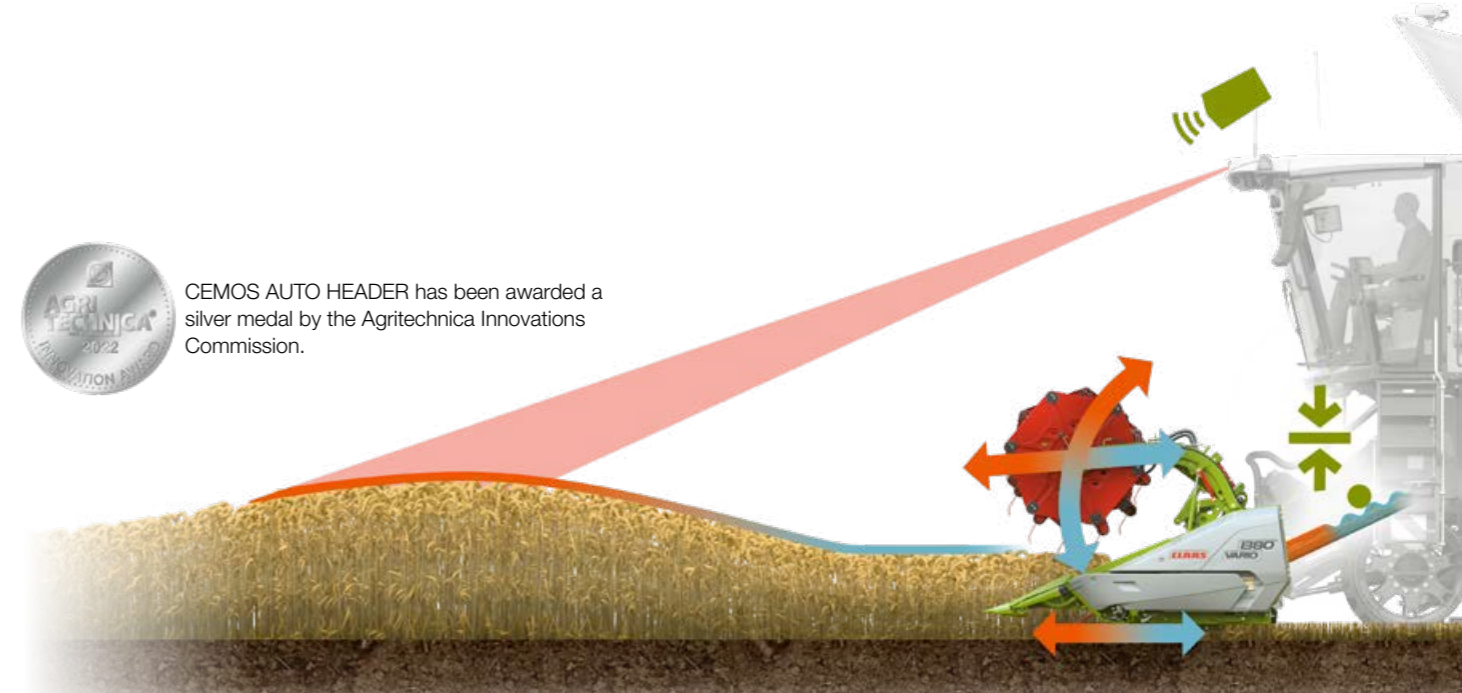

CEMOS DIALOG

motivates you like never before.

Greater safety and reliability in the field.

Controlled through CEBIS, the CEMOS DIALOG operator assistance system guides you to the optimal machine setup. Settings which are confirmed by you are implemented directly by CEMOS DIALOG. You are motivated to check the settings more frequently and also benefit from the learning effects.

CEMOS analyses the machine's performance.

The machine always keeps you informed about the scope for optimisation. It continuously indicates all the factors imposing the greatest limitations on throughput and actively suggests ways to increase performance. It even calibrates the sensitivity of the loss sensors automatically while running. If you change the accepted loss level during harvesting, CEMOS DIALOG automatically adjusts the sensitivity of the sensors. There is no need for another loss measurement to be performed.

CEMOS Advisor app supports you.

The free CEMOS Advisor smartphone app helps you find the optimal machine setting. The grain loss calculation is already integrated in this valuable adjustment aid.

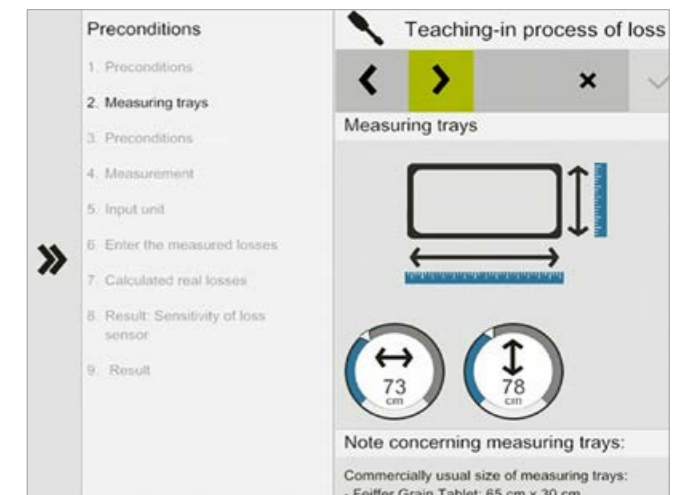

The dimensions of the loss control pan being used are entered in CEBIS.

Adjusting the sensitivity.

This is a situation you will recognise: you start harvesting in the morning with a loss level of 0.5%. In the afternoon, there is a risk of rain. You want to adjust the loss limit to 1%. As soon as you enter the new loss value, CEMOS DIALOG automatically determines the corresponding value for the sensitivity of the loss sensors. CEMOS AUTOMATIC runs the machine at the maximum loss limit again and optimises the throughput. This saves you a lot of time, as there is no need for another measurement of losses to be performed with a loss control pan.

Harvest right up to the grain loss limit.

- You only have to calibrate the loss sensors at the start of the day.
- CEMOS DIALOG actively supports you with loss measurements.
- After the loss level has been changed, the sensitivity of the sensors is corrected automatically.
- The machine always works precisely up to the limit set for acceptable losses.

Determine losses.

Increase campaign performance.

Setting the correct loss rate plays a decisive role in increasing your campaign performance. An accurately set grain loss ratio ensures that you do not waste any power. Once the losses have been determined and the sensitivity of the loss sensors has been adjusted accordingly, CEMOS AUTOMATIC applies the optimal settings. In this way, the system always brings the machine precisely up to the limit of acceptable losses. Another benefit of this system is that it prevents the entry of incorrect values which could slow the machine down.

Loss sensor programming.

CEMOS DIALOG supports you when it comes to calibrating the loss sensors for the separation and cleaning stages. You can use the same loss control pan which you are already using. The system guides you steadily, step-by-step, through the loss measurements. It asks you to input the dimensions of your loss control pan and tells you when to deploy it.

Once you have entered the measurements obtained with the loss control pan (volume, weight or number of grains), CEMOS DIALOG suggests a value for the sensitivity of the loss sensors. The better the sensor sensitivity setting, the more precise the loss indication. These data allow CEMOS AUTOMATIC to set up the machine to operate more efficiently.

The LEXION: precision harvesting like never before.

Keep the number of passes to a minimum.

Steering systems are an essential tool in your everyday work. The LEXION can be equipped with three automatic steering systems, which you can choose between on the basis of the task in question: the digital AUTO PILOT, the satellite-based GPS PILOT CEMIS 1200 and the electro-optical LASER PILOT with FIELD SCANNER.

Precision for every task.

- The GPS PILOT steers precisely and can be controlled intuitively via CEMIS 1200.
- The LASER PILOT with FIELD SCANNER offers you three different steering modes.
- The AUTO PILOT helps you work precisely in maize.
- With dynamic steering you can turn quickly and easily at the end of the field.

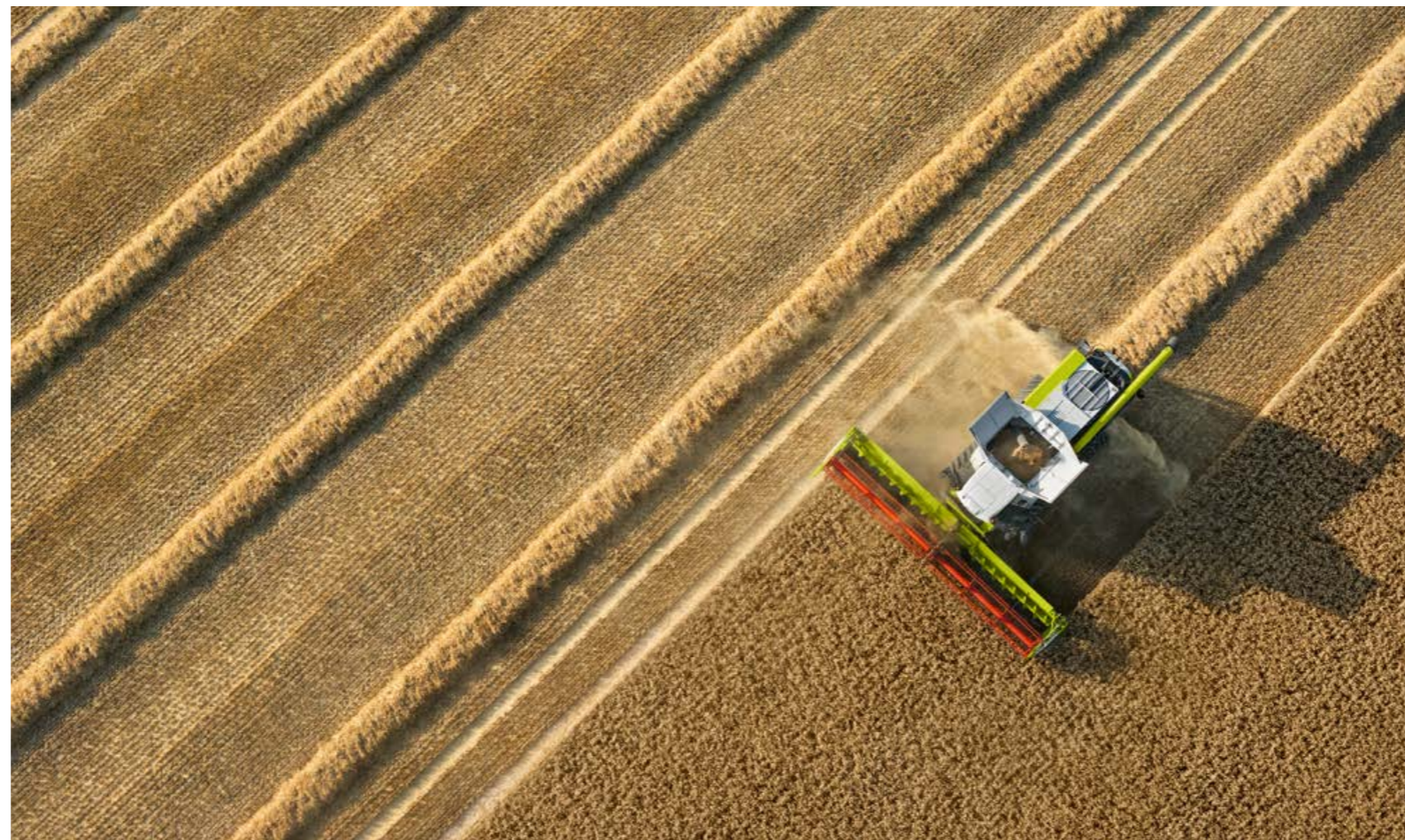

GPS PILOT with unbeatable steering precision.

The satellite-based automatic steering system from CLAAS is permanently integrated in the machine. It supports you in all tasks which depend on high pass-to-pass accuracy. You start the GPS PILOT via the multifunction lever. It actively controls the steering hydraulics and guides you across the field precisely at all speeds, regardless of the light conditions. It works at night or in low visibility just as precisely as it does in full daylight. You receive correction signals for whichever degree of accuracy you require.

NEW: CEMIS 1200 terminal with intuitive control.

With CEMIS 1200 you have an entirely new steering terminal in the cab of your combine harvester. You can count on its support for precision GPS tracking. It also allows you to handle all the common precision farming applications. You can map your yields in real time, manage your jobs and document them directly on the machine. You will be familiar with the control logic from your CEBIS. CEBIS 1200 can be controlled just as intuitively.

- The brilliant 12" display is easy to read by day or night.
- All the relevant functions are available with direct access.
- You can adapt the working areas in line with your requirements and configure them freely.

LASER PILOT with FIELD SCANNER.

As an option, you can replace the sensor on the outer edge of the cutterbar with a FIELD SCANNER which is fitted centrally on the cab roof.

There is no need to fold the scanner out or in. Calibration is also no longer required. A button on the armrest is used to activate three steering modes: along the edge of the crop to the right or left or along the tramline.

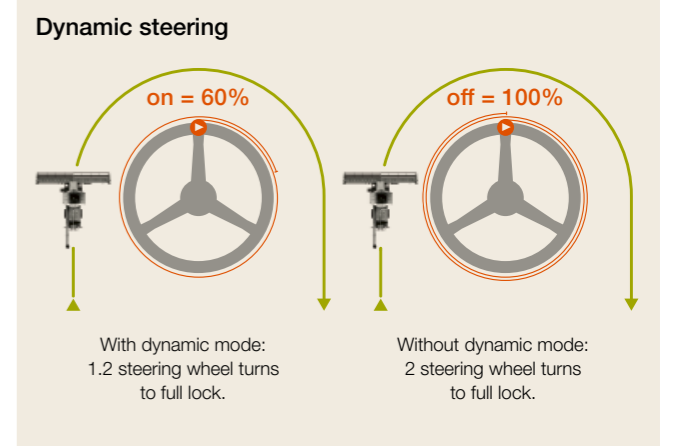

NEW: Dynamic steering for fast turning.

You steer the LEXION with about four steering wheel turns from lock to lock. If you prefer a less demanding steering input when you have to turn at the end of the field, you can activate the dynamic steering system. This reduces by 40% the extent to which the steering wheel has to be turned to go from straight-ahead running to full lock. This functionality is conditional on a speed of less than 10 km/h.

AUTO PILOT.

Two digital sensors incorporated in one of the snapping units of the maize picker guide the LEXION automatically through the rows of maize, thereby ensuring it is in the optimal position in the crop.

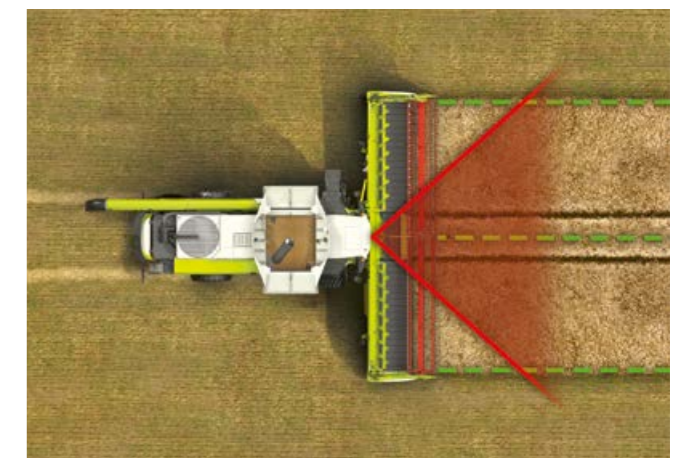

LASER PILOT
with FIELD SCANNER.



Scan me.

You can find the ideal CLAAS steering system for your LEXION here.

A connected LEXION is more productive.

Digitalisation pays.

Digitalisation is a key factor in increasing your productivity and efficiency. Data generated in completely different places can be collected and evaluated centrally. This conserves your resources and improves your business processes.

To enable you to get more out of the LEXION and your other machines, CLAAS offers a range of modules which allow systems, technology and working processes to be connected with each other, regardless of the manufacturer. Intelligent digitalisation matched to the requirements of your farm can reduce your workload significantly.

- Transmit and document machine and job data quickly.
- Manage machines and the fleet efficiently.
- Analyse working processes intensively and optimise them.
- Analyse fields easily and map yields precisely.
- Call up and manage farm data with intelligent farm management software.
- Transmit data from different manufacturers' products in TELEMATICS smoothly.
- Save valuable maintenance and service time with remote diagnostics.

TELEMATICS records your success.

Work data, tracks and yield data for your combine harvester can be retrieved and recorded continuously by means of TELEMATICS. All data are transmitted via the mobile phone network from the machine to the server, where they are processed and stored. You can access and evaluate your data online in real time or retrospectively via the web portal or the TELEMATICS app. The Connected Documentation licence amalgamates all the data on a field-specific basis in the background. It is also possible to export your data to any current farm management software program.

DataConnect transmits data regardless of manufacturer.

In addition, the CLAAS API is able to connect your TELEMATICS account to a farm management software system. This allows the secure, convenient and fully automatic exchange of all the relevant data. Both systems are components of CLAAS TELEMATICS.

With the DataConnect function, CLAAS, 365FarmNet, John Deere, Case, Steyr and New Holland have created a direct, multi-manufacturer, industry-wide and open cloud-to-cloud solution. This allows you to control and monitor your entire machinery fleet in the CLAAS TELEMATICS portal.

Remote Service costs you nothing.

Remote Service from CLAAS is an important machine connection element. It simplifies maintenance and service support significantly. The machine informs the service partner of an upcoming requirement for maintenance or sends immediate notification if a fault arises. The service partner has access to the relevant data and can prepare optimally for the intervention in both scenarios. CLAAS covers the cost of Remote Service for you during the first five years. All you have to do is give your consent.

FLEET VIEW coordinates the fleet.

With FLEET VIEW, you can coordinate the grain transport team in your harvesting fleet in such a way that the combine harvesters can keep on working without idle time. The app informs you in real time about the position of the machines and their grain tank fill levels. In this way you can avoid idle time and unnecessary vehicle travel, save fuel and make full use of the harvesting machines' capacity.

NEW: CEMIS 1200 manages your jobs.

With CEMIS 1200 and an active Connected Documentation licence, you can perform job management tasks in the office or on the spot in the machine. You transmit the data online. New jobs specific to particular fields or customers can be created intuitively. You can also map your yields in real time and call up a display of yield maps.

NEW: CEMOS CONNECT makes all operators as good as the best.

CEMOS CONNECT links all the combine harvesters in a fleet via the internet. The data relating to the settings of the various stages of a combine harvester can be transmitted from the machine of an experienced operator to all the others. If the transmitting machine is equipped with CEMOS AUTOMATIC, all the other machines automatically operate at the same high level of efficiency.



Digitalisation puts your farm ahead.

- With TELEMATICS you transmit data from the machine straight to the cloud.
- With CEMIS 1200 you create and manage all jobs on the spot in the machine.
- DataConnect allows you to process the data from your machines, regardless of manufacturer.
- With Remote Service you simplify maintenance and service activities.

Fast maintenance is crucial for your harvest.



Reduced daily maintenance requirement.

Like all its predecessors, the LEXION is also appreciated for being a model of restraint where maintenance requirements are concerned. The maintenance intervals are long: 1,000 hours for the oil in the working hydraulics. Daily maintenance tasks can be carried out quickly and effortlessly. All the key maintenance points can be accessed easily.

Reliable lubrication.

The central lubrication system supplies grease to all the lubrication service points, including the variators, as required. Lubrication points and intervals only need to be programmed once.



Optimal accessibility.

The robust engine compartment cover makes it particularly easy for you to access the grain tank and to perform any maintenance tasks required there. It is slip-resistant and designed to be walked on. Handrails and a folding step provide additional safety.

- All the maintenance points around the machine are easily accessible.
- Contact points for the mobile ladders enable safe access for maintenance and cleaning tasks.
- The side panels, steps and engine compartment are brightly lit.

More time for harvesting.

- The centrally routed drain hoses for engine oil and hydraulic oil are easily accessible.
- All the variators are connected to the central lubrication system.
- The air compressor with a reservoir enables cleaning tasks to be performed quickly, even in the field.
- The grain tank can be accessed easily via the divided engine compartment cover which is designed to be walked on.

Well thought-out convenience package.

The convenient maintenance package features a number of practical solutions to make daily maintenance tasks more user-friendly:

- Secure bracket for the grease gun
- Removable water tank with 15 litre capacity
- Separate drain cock for hand washing on side of tool compartment

Automatic air hose reel.

The convenient maintenance package of the new LEXION also includes an air hose reel with a 15 m compressed air hose which can be unwound and wound up easily and tidily. The reel is locked as soon as you have unwound the hose. Pulling on the hose briefly causes it to be wound up again automatically. This feature makes fast interim cleaning in the course of the day even more convenient.



The LEXION adapts quickly to changing requirements.

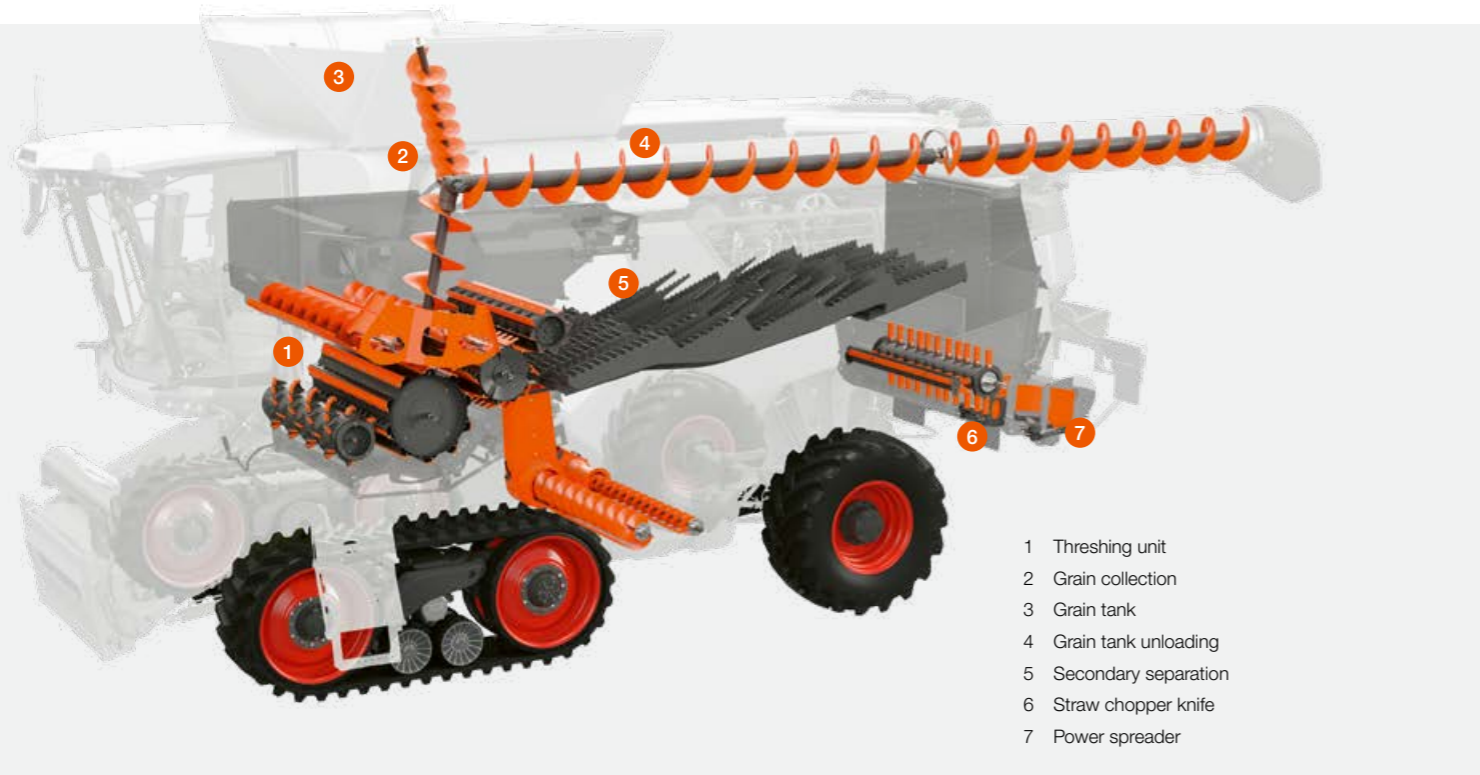

- 1 Threshing unit
- 2 Grain collection
- 3 Grain tank
- 4 Grain tank unloading
- 5 Secondary separation
- 6 Straw chopper knife
- 7 Power spreader

Conversion in next to no time.

Every minute the LEXION is not standing in the yard benefits your harvest. This applies not only to daily maintenance, but also to changeover tasks and the replacement of wear parts which you only have to perform from time to time. Changing the threshing concave or adjusting the speed of the threshing drum and straw chopper are typical examples. We have designed the LEXION in such a way that all these tasks require as little effort as possible.

Replace wear parts less often.

All components subject to particularly heavy wear and tear in the crop flow are optionally available in PREMIUM LINE quality. These are the right choice when you have to harvest under extreme conditions which are particularly hard on your combine harvester.

PREMIUM LINE components are extra resistant to wear and corrosion and have a very long service life. Even with intensive annual use or when subjected to aggressive crops, these parts will not usually have to be changed until after several campaigns. This increased durability is achieved through special manufacturing processes, high-quality materials and special coatings.

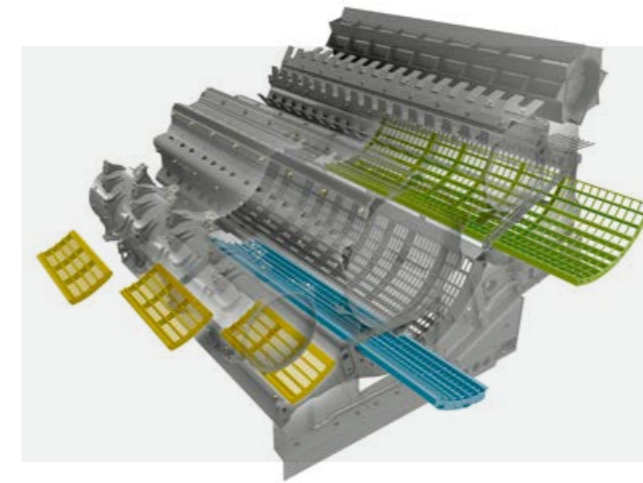

Change concave segments more quickly.

When you want to change from one crop to another and prepare the LEXION for maize harvesting after the grain harvest, for example, you can look forward to short changeover times. The main components of the threshing concave remain in the machine. You can change the preconconcave segments quickly through the stone trap. The threshing concave segment is simply pulled out to the side.

Speed adjustment without tools.

Depending on the crop, the threshing drum needs to run at different speeds. The threshing drum speed reduction gearbox allows you to change quickly between two speed ranges. In the low range, speeds from 170-460 rpm are available while the high range offers 330-930 rpm.



Even in the mechanical variant, the speed range can be adjusted without the need for tools. If you want to save even more time, choose the hydraulically adjustable version (optional). You can then perform the adjustment from the comfort of the cab.

Simply leave the same straw chopper knives in the machine.

Adjusting the straw management system also takes next to no time. If you choose wear-resistant PREMIUM LINE chopper knives, you benefit from components with a long service life which require replacement less frequently.

Universal chopper knives for grain and maize in PREMIUM LINE quality.

These wear-resistant chopper knives are suitable for both grain and maize harvesting. When you change crop, you can simply leave the same knives in the machine.

Every minute is precious

- Extra wear-resistant PREMIUM LINE components require less frequent replacement.
- The preconconcave segments are changed quickly through the stone trap.
- The threshing concave segment is simply pulled out to the side.
- You can adjust the threshing drum speed without tools or, with hydraulic assistance, from the cab (optional).
- When changing crop from grain to maize, the same chopper knives remain in the machine.

Whatever it takes – CLAAS Service & Parts.



Safeguard your machine's reliability.

Increase your operating reliability, minimise the repair and breakdown risk. MAXI CARE offers you predictable costs. Create your own individual service package to meet your particular requirements.

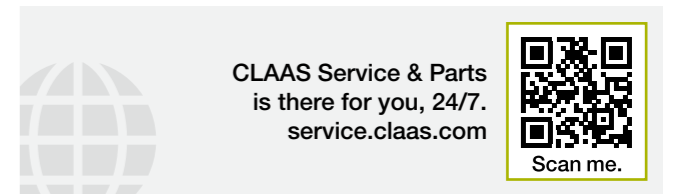

Specially matched to your machine.

Precision-manufactured parts, high-quality consumables and useful accessories. Choose our comprehensive product range to be certain of receiving exactly the right solution to ensure 100% operating reliability for your machine.



Get connected.

Remote Service allows your sales and service partner to access your machine and your specific data directly. This allows you and your CLAAS partner to respond quickly to maintenance and servicing situations. And with CLAAS TELEMATICS, you can access all of your important machine data via the internet, anytime, anywhere.



Global supply.

The CLAAS Parts Logistics Center in Hamm, Germany, stocks almost 200,000 different parts and has a warehouse area of over 183,000 m². This central spare parts warehouse delivers all ORIGINAL parts quickly and reliably all over the world. This means that your local CLAAS partner can supply the right solution for your harvest or your farm within a very short time.



Your local CLAAS distributor.

Wherever you are, you can count on us to always provide you with the service and the contact persons you need. Your CLAAS partners are on hand in your local area, ready to support you and your machine around the clock. With know-how, experience, commitment and the best technical equipment. Whatever it takes.



- | | | |
|---------------------------------------|---|--------------------------------------|
| 1 Comfort cab | 8 Grain elevator with QUANTIMETER | 15 SPECIAL CUT chopper |
| 2 CEMOS AUTOMATIC | 9 Grain tank with up to 13,500 l | 16 Chaff blower |
| 3 Feeder housing with dust extraction | 10 Pivoting spout | 17 Power spreader |
| 4 APS SYNFLOW WALKER threshing unit | 11 Grain tank unloading at up to 180 l/s | 18 TERRA TRAC with 40 km/h top speed |
| 5 Separator drum | 12 Cover flap for grain tank unloading tube | 19 Separate returns pan |
| 6 JET STREAM cleaning | 13 DYNAMIC COOLING | 20 3D cleaning system |
| 7 High-performance straw walker | 14 Perkins engines | |



Machine of the year 2020



Agritechnica Innovation Award 2019:
CEMOS AUTO CHOPPING



Agritechnica Innovation Award 2022:
CEMOS AUTO HEADER



Efficiency.

- APS SYNFLOW WALKER increases throughput and straw quality.
- Large threshing and separator drums provide a straight, even and fast crop flow.
- DYNAMIC COOLING provides cooling as required
- DYNAMIC POWER for fuel savings of up to 10%.
- JET STREAM cleans your grain impeccably.
- 13,500 l unloaded in 75 s.
- 40 km/h gets you there quickly.
- CLAAS cutterbars deliver an optimal crop flow, right from the start.



Precision.

- CEMOS AUTOMATIC continuously optimises threshing unit, cleaning system and crop flow.
- CEMOS AUTO THRESHING in CEBIS adjusts the threshing drum speed, threshing concave distance, threshing concave bar and flap.
- AUTO SLOPE reduces your workload on slopes.
- LASER PILOT and GPS steering keep the number of passes to a minimum.
- CEMOS AUTO CHOPPING optimises the chopped material quality and reduces fuel consumption.
- CEMOS AUTO HEADER optimises the crop flow right from the cutterbar.
- CEMIS 1200 provides precise steering and precise documentation.
- TELEMATICS documents job data, tracks and yield data and transmits them to the cloud.



Comfort.

- The comfort cab with its new air conditioning concept provides plenty of headroom and legroom.
- The CEBIS touchscreen is as easy to use as your smartphone.
- Operation of the CMOTION multifunction lever is intuitive.
- The direct adjustment function in the armrest allows you to access the most important functions.
- You can react quickly to crop type changes.
- The new 105° pivot angle improves the view of the grain tank unloading tube.
- LED lighting packages turn night into day.
- The pivoting spout on the grain tank unloading tube directs the stream precisely.



Reliability.

- The revised drive system impresses with its high efficiency.
- The main drive engages gently via the dry clutch.
- The use of belt conveyors instead of chains makes for smoother running and an extended service life.
- The central lubrication system supplies all lubrication points, including the variators.
- PREMIUM LINE components: extra resistance to wear and a very long service life.
- Flexible MAXI CARE service products increase operational reliability.
- Remote Service simplifies maintenance and service support.
- All the maintenance points around the machine are easily accessible.



LEXION LEXION TERRA TRAC (TT)		6800	6800 TT	6700	6700 TT
Threshing unit and primary separation					
APS SYNFLOW WALKER		●	●	●	●
Threshing drum width	mm	1700	1700	1700	1700
Threshing drum diameter	mm	755	755	755	755
Threshing drum speed	rpm	330-930	330-930	330-930	330-930
With reduction gear	rpm	170-460 / 330-930	170-460 / 330-930	170-460 / 330-930	170-460 / 330-930
Threshing concave wrap angle	degrees	132	132	132	132
Main concave area	m²	1.55	1.55	1.55	1.55
Rice threshing unit		–	–	–	–
Secondary separation					
Separator drum diameter	mm	600	600	600	600
Separator concave area	m²	1.16	1.16	1.16	1.16
Contact angle separator drum	degrees	116	116	116	116
Straw walker	No.	6	6	6	6
Straw walker length	mm	3800	3800	3800	3800
Total secondary separation area	m²	7.62	7.62	7.62	7.62
Crop cleaning					
JET STREAM		●	●	●	●
Turbine fan		8-way	8-way	8-way	8-way
Fan adjustment, hydraulic		●	●	●	●
Dual ventilated step		●	●	●	●
3D cleaning system		○	○	○	○
Total sieve area	m²	6.20	6.20	6.20	6.20
Returns display in CEBIS		○	○	○	○
GRAINMETER		○	○	○	○
Grain tank					
Capacity (as per ANSI/ASAE S312.2)	l	12500 / 13500	12500 / 13500	11000 / 12500	11000 / 12500
Unloading auger swivel angle	degrees	105	105	105	105
Pivoting unloading spout		○	○	○	○
Unloading rate	l/s	130/180	130/180	130/110	130/110
QUANTIMETER yield meter		○	○	○	○
Chopper					
SPECIAL CUT straw chopper, knives	No.	88	88	88	88
STANDARD CUT straw chopper, knives	No.	64	64	64	64
Power spreader		○	○	○	○
Hydraulic changeover from cab (road travel, swathing, chopping)		○	○	○	○
Hydraulic adjustment of static knife and friction concave plate		○	○	○	○
Chaff spreader		○	○	○	○
Chaff blower with power spreader		○	○	○	○
Automatic discharge direction adjustment		○	○	○	○

● Standard ○ Option □ Available – Not available

LEXION LEXION TERRA TRAC (TT)		6800	6800 TT	6700	6700 TT
Chassis					
TERRA TRAC crawler tracks with hydropneumatic suspension		○	○	○	○
POWER TRAC all-wheel drive		○	○	○	○
2-speed manual gearbox		●	●	●	●
40 km/h		○	○	○	○
Differential lock for wheeled machine		○	○	○	○
Car-like driving characteristics		●	●	●	●
Engine Stage III A (Tier 3)					
Manufacturer / Type		Perkins 2206D	Perkins 2206D	Perkins 2206D	Perkins 2206D
Cylinders / displacement	No./l	6/12.5	6/12.5	6/12.5	6/12.5
Maximum output (ECE R 120)	kW/hp	339/461	339/461	308/419	308/419
Fuel consumption measurement		○	○	○	○
Fuel tank capacity	l	950	950	950	950
DYNAMIC COOLING		●	●	●	●
DYNAMIC POWER		●	●	●	●
Data management					
TELEMATICS		●	●	●	●
Job management		○	○	○	○
Yield mapping		○	○	○	○
Remote Service		○	○	○	○
Operator assistance systems					
CRUISE PILOT		○	○	○	○
CEMOS AUTO THRESHING		○	○	○	○
CEMOS AUTO CLEANING		○	○	○	○
CEMOS AUTO CHOPPING		○	○	○	○
CEMOS AUTO HEADER		○	○	○	○
AUTO SLOPE		○	○	○	○
AUTO CROP FLOW		○	○	○	○
CEMOS DIALOG		○	○	○	○
GRAIN QUALITY CAMERA		○	○	○	○
Steering systems					
GPS PILOT, CEMIS 1200, LASER PILOT with FIELD SCANNER, AUTO PILOT		○	○	○	○
Weights (can vary depending on equipment) without front attachment, straw chopper and chaff spreader, full fuel tank, full urea tank	kg	17050	19450	17050	19450

CLAAS continually develops its products to meet customer requirements. This means that all products are subject to change without notice. All descriptions and specifications in this brochure should be considered approximate and may include optional equipment that is not part of the standard specifications. This brochure is designed for worldwide use. Please refer to your nearest CLAAS dealer and their price list for local specification details. Some protective panels may have been removed to present the function more clearly in photographs. To avoid any risks, you should never remove these protective panels yourself. In this context, please refer to the relevant instructions in the operator's manual. All technical specifications relating to engines are based on the European emission regulation standards: Stage. Any reference to the Tier standards in this document is intended solely for information purposes and ease of understanding. It does not imply approval for regions in which emissions are regulated by Tier.

● Standard ○ Option □ Available – Not available

LEXION LEXION TERRA TRAC (TT)			6800	6800 TT	6700	6700 TT
Drive axle tyre size		Ø cat.				
1250/50 R 32	m	2.05	4.93	4.93	4.93	4.93
900/60 R 42 CHO	m	2.15	3.90	3.90	–	–
800/70 R 42 CHO	m	2.15	3.76	3.76	–	–
680/80 R 42 CHO	m	2.15	3.49	3.49	–	–
VF 900/60 R 38 CHO	m	2.05	3.90	3.90	3.90	3.90
900/60 R 38 CHO	m	2.05	3.90	3.90	3.90	3.90
IF 800/70 R38 CFO	m	2.05	3.76	3.76	3.76	3.76
800/70 R 38 CHO	m	2.05	3.76	3.76	3.76	3.76
680/80 R 38 CHO	m	2.05	3.49	3.49	3.49	3.49
900/60 R 32	m	1.95	3.90	3.90	3.90	3.90
IF 800/70 R 32 CFO	m	1.95	3.76	3.76	3.76	3.76
800/70 R 32	m	1.95	3.76	3.76	3.76	3.76
710/75 R 34	m	1.95	3.65	3.65	3.65	3.65
IF 680/85 R 32 CFO	m	1.95	3.49	3.49	3.49	3.49
680/85 R32	m	1.95	3.49	3.49	3.49	3.49
TERRA TRAC 635 mm	m	–	–	3.49	–	3.49
TERRA TRAC 735 mm	m	–	–	3.79	–	3.79
TERRA TRAC 890 mm	m	–	–	3.99	–	3.99
Steering axle tyre size		Ø cat.				
750/65 R 26	m	1.60	3.96	3.96	–	–
710/60 R 30	m	1.65	3.89	3.89	–	–
VF 620/70 R 30	m	1.65	3.69	3.69	–	–
620/70 R 30	m	1.65	3.70	3.70	–	–
VF 520/85 R 30	m	1.65	3.49	3.49	–	–
500/85 R 30	m	1.65	3.48	3.48	–	–
VF620/70 R 26	m	1.50	3.69	3.69	3.69	3.69
600/65 R 28	m	1.50	3.70	3.70	3.69	3.69
500/85 R 24	m	1.50	3.48	3.48	3.48	3.48

LEXION LEXION TERRA TRAC (TT)			6800	6800 TT	6700	6700 TT
Front attachments						
VARIO cutterbars			VARIO 1230 ¹ , VARIO 1080, VARIO 930, VARIO 770, VARIO 680, VARIO 620, VARIO 560, VARIO 500			
CERIO cutterbars			CERIO 930, CERIO 770, CERIO 680, CERIO 620, CERIO 560			
Rapeseed equipment			For all CONVIO / CONVIO FLEX and VARIO cutterbars			
Folding cutterbars			C 540, C 450			
CORIO maize picker	rows		12, 8, 6			
SUNSPEED	rows		16, 12, 8			
MAFLEX			MAXFLEX 930, MAXFLEX 770, MAXFLEX 620, MAXFLEX 560			
CONVIO FLEX			CONVIO FLEX 1230 ¹ , CONVIO FLEX 1080, CONVIO FLEX 930, CONVIO FLEX 770			
CONVIO			CONVIO 1230 ¹ , CONVIO 1080, CONVIO 930, CONVIO 770			
SWATH UP			SWATH UP 450			
Front attachment variable speed drive (electrohydraulic)	rpm		284-420			
Front attachment step drive	rpm		332, 420			
Instant cutterbar brake			o			

¹ Only for LEXION with TERRA TRAC



CLAAS KGaA mbH
Mühlenwinkel 1
33428 Harsewinkel
Deutschland
Tel. +49 5247 12-0
claas.com